



# 30HXC 075-370 30GX 080-350 Screw Compressor Water-Cooled Chillers and Air-Cooled Chillers

30HXC Nominal cooling capacity 268-1290 kW  
30GX Nominal cooling capacity 262-1160 kW  
50 Hz



Installation, operation and maintenance instructions



**The cover photograph is for illustrative purposes only  
and is not part of any offer for sale or contract.**

# List of contents

<b>INTRODUCTION</b> .....	<b>4</b>	<b>FIELD POWER SUPPLY</b> .....	<b>28</b>
<b>SAFETY CONSIDERATIONS</b> .....	<b>4</b>	30HXC 075-185 .....	28
<b>DIMENSIONS, CLEARANCES, WEIGHT DISTRIBUTION</b> .....	<b>5</b>	30HXC 215-280 .....	29
30HXC 075-185 .....	5	30HXC 300-370 .....	30
30HXC 215-280 .....	6	30GX 080-160 .....	31
30HXC 300-370 .....	7	30GX 175 .....	32
30GX 080-160 .....	8	30GX 205-265 .....	33
30GX 175 .....	9	30GX 280-350 .....	34
30GX 205-265 .....	10	<b>MAJOR SYSTEM COMPONENTS AND OPERATION DATA</b> .....	<b>35</b>
30GX 280-350 .....	11	Geared twin screw compressor .....	35
<b>MAIN COMPONENT LOCATION</b> .....	<b>12</b>	Cooler .....	35
30HXC 075-185 .....	12	Condenser and oil separator (30HXC) .....	35
30HXC 215-280 .....	13	Oil separator (30GX) .....	35
<b>PHYSICAL DATA</b> .....	<b>14</b>	Electronic Expansion Device (EXD) .....	35
30HXC .....	14	Economizer .....	35
<b>ELECTRICAL DATA</b> .....	<b>15</b>	Oil pumps .....	36
30HXC .....	15	Motor cooling valves .....	36
Compressor .....	15	Back pressure valve (GX only) .....	36
<b>PHYSICAL DATA</b> .....	<b>16</b>	Sensors .....	36
30GX .....	16	Thermistors .....	36
<b>ELECTRICAL DATA</b> .....	<b>17</b>	Pressure transducers .....	36
30GX .....	17	Control components .....	37
Compressor .....	17	<b>CONTROL OPERATION</b> .....	<b>39</b>
<b>APPLICATION DATA</b> .....	<b>18</b>	Keypad and display module usage (HSIO II) .....	39
Unit operating range .....	18	Functions and subfunctions .....	39
Minimum chilled water flow .....	18	Accessing functions and subfunctions .....	40
Maximum chilled water flow .....	18	Status function .....	41
Cooler flow rate (l/s) .....	19	Test function and subfunctions .....	43
Condenser flow rate (l/s) .....	19	Schedule function .....	44
Variable flow evaporator .....	19	Service function .....	44
System minimum water volume .....	19	History function and subfunctions .....	46
Flow controllers .....	20	Setpoint function .....	47
<b>INSTALLATION</b> .....	<b>20</b>	Head pressure control .....	48
Check equipment received .....	20	<b>PRE-START-UP PROCEDURE</b> .....	<b>50</b>
Moving and siting the unit .....	20	System Check .....	50
<b>LIFTING INSTRUCTIONS</b> .....	<b>21</b>	Start-up and operation .....	50
30HXC 075-185 .....	21	Actual Start-up .....	50
30HXC 215-280 .....	22	Operating Sequence .....	50
30HXC 300-370 .....	23	<b>TROUBLESHOOTING</b> .....	<b>51</b>
30GX 080-160 .....	24	Checking display codes .....	51
30GX 175 .....	24	Unit shutoff .....	51
30GX 205-265 .....	25	Complete unit stoppage .....	51
30GX 280-350 .....	25	Single Circuit Stoppage .....	51
<b>PIPING CONNECTIONS</b> .....	<b>26</b>	Restart procedure .....	51
Operating precautions .....	26	Alarms and alert .....	51
Cooler and condenser connections .....	26	Alarms and alerts codes table .....	52
Pipe connections .....	26	Low oil pressure alert criteria and setpoints (Alert 40 to 43) .....	56
Freeze protection .....	26	<b>MAINTENANCE</b> .....	<b>57</b>
<b>ELECTRICAL CHARACTERISTICS</b> .....	<b>27</b>	Refrigerant Charging - Adding Charge .....	57
Power supply .....	27	Oil Charging - Low oil recharging .....	58
		Service replacement compressor .....	59
		EXV Troubleshooting Procedure .....	59
		<b>START-UP CHECKLIST FOR 30HXC/30GX</b> .....	<b>60</b>
		Preliminary information .....	60
		Preliminary equipment check .....	60
		Unit start-up .....	61

## INTRODUCTION

Prior to initial start-up of the 30HXC and 30GX unit, those involved in the start-up, operation, and maintenance should be thoroughly familiar with these instructions and other necessary job data. This book provides an overview so that you may become familiar with the control system before performing start-up procedures. Procedures in this manual are arranged in the sequence required for proper machine start-up and operation.

## SAFETY CONSIDERATIONS

30HXC and 30GX liquid chillers are designed to provide safe and reliable service when operated within design specifications. When operating this equipment, use good judgment and safety precautions to avoid damage to equipment and property or injury to personnel.

Be sure you understand and follow the procedures and safety precautions contained in the machine instructions as well as those listed in this guide.

### **DANGER**

**DO NOT VENT** refrigerant relief valves within a building. Outlet from relief valve must be vented outdoors. The accumulation of refrigerant in an enclosed space can displace oxygen and cause asphyxiation.

**PROVIDE** adequate ventilation, especially for enclosed and low overhead spaces. Inhalation of high concentrations of vapor is harmful and may cause heart irregularities, unconsciousness, or death. Misuse can be fatal. Vapor is heavier than air and reduces the amount of oxygen available for breathing. Product causes eye and skin irritation. Decomposition products are hazardous.

**DO NOT USE OXYGEN** to purge lines or to pressurize a machine for any purpose. Oxygen gas reacts violently with oil, grease, and other common substances.

**NEVER EXCEED** specified test pressures, **VERIFY** the allowable test pressure by checking the instruction literature and the design pressures on the equipment nameplate.

**DO NOT USE** air for leak testing. Use only refrigerant or dry nitrogen.

**DO NOT VALVE OFF** any safety device.

**BE SURE** that all pressure relief devices are properly installed before operating any machine.

### **WARNING**

**DO NOT WELD OR FLAMECUT** any refrigerant line or vessel until all refrigerant (liquid and vapor) has been removed from chiller. Traces of vapor should be displaced with dry air nitrogen and the work area should be well ventilated. Refrigerant in contact with an open flame produces toxic gases.

**DO NOT** work on high-voltage equipment unless you are a qualified electrician.

**DO NOT WORK ON** electrical components, including control panels, switches, relays etc, until you are sure **ALL POWER IS OFF** and residual voltage can leak from capacitors or solid state components.

**LOCK OPEN AND TAG** electrical circuits during servicing. **IF WORK IS INTERRUPTED**, confirm that all circuits are de-energized before resuming work.

**DO NOT** siphon refrigerant.

**AVOID SPILLING** liquid refrigerant on skin or getting it into the eyes. **USE SAFETY GOGGLES.** Wash any spills from the skin with soap and water. If liquid refrigerant enters the eyes,

**IMMEDIATELY FLUSH EYES** with water and consult a physician.

**NEVER APPLY** an open flame or live steam to refrigerant cylinder. Dangerous overpressure can result. If it is necessary to heat refrigerant, use only warm water.

**DO NOT REUSE** disposable (non-returnable) cylinders or attempt to refill them. It is **DANGEROUS AND ILLEGAL.** When cylinders are emptied, evacuate remaining gas pressure, loosen the collar and unscrew and discard the valve stem. **DO NOT INCINERATE.**

**CHECK THE REFRIGERANT TYPE** before adding refrigerant to the machine. The introduction of the wrong refrigerant can cause damage or malfunction to this machine. **DO NOT ATTEMPT TO REMOVE** fittings, components, etc., while machine is under pressure or while machine is running. Be sure pressure is at 0 kPa before breaking refrigerant connection.

**CAREFULLY INSPECT** all relief devices, **AT LEAST ONCE A YEAR.** If machine operates in a corrosive atmosphere, inspect the devices at more frequent intervals.

**DO NOT ATTEMPT TO REPAIR OR RECONDITION** any relief device when corrosion or build-up of foreign material (rust, dirt, scale, etc.) is found within the valve body or mechanism. Replace the device.

**DO NOT** install relief devices in series or backwards.

### **CAUTION**

**DO NOT STEP** on refrigerant lines. Broken lines can whip about and release refrigerant, causing personal injury.

**DO NOT** climb over a machine. Use platform, or staging.

**USE MECHANICAL EQUIPMENT** (crane, hoist, etc.) to lift or move heavy components. Even if components are light, use mechanical equipment when there is a risk of slipping or losing your balance.

**BE AWARE** that certain automatic start arrangements **CAN ENGAGE TOWER FAN, OR PUMPS.** Open the disconnect ahead of the tower fans, or pumps.

**USE** only repair or replacement parts that meet the code requirements of the original equipment.

**DO NOT VENT OR DRAIN** water boxes containing industrial brines, without the permission of your process control group.

**DO NOT LOOSEN** water box bolts until the water box has been completely drained.

**DO NOT LOOSEN** a packing gland nut before checking that the nut has a positive thread engagement.

**PERIODICALLY INSPECT** all valves, fittings, and piping for corrosion, rust, leaks, or damage.

**PROVIDE A DRAIN** connection in the vent line near each pressure relief device to prevent a build-up of condensate or rain water.

# DIMENSIONS, CLEARANCES, WEIGHT DISTRIBUTION

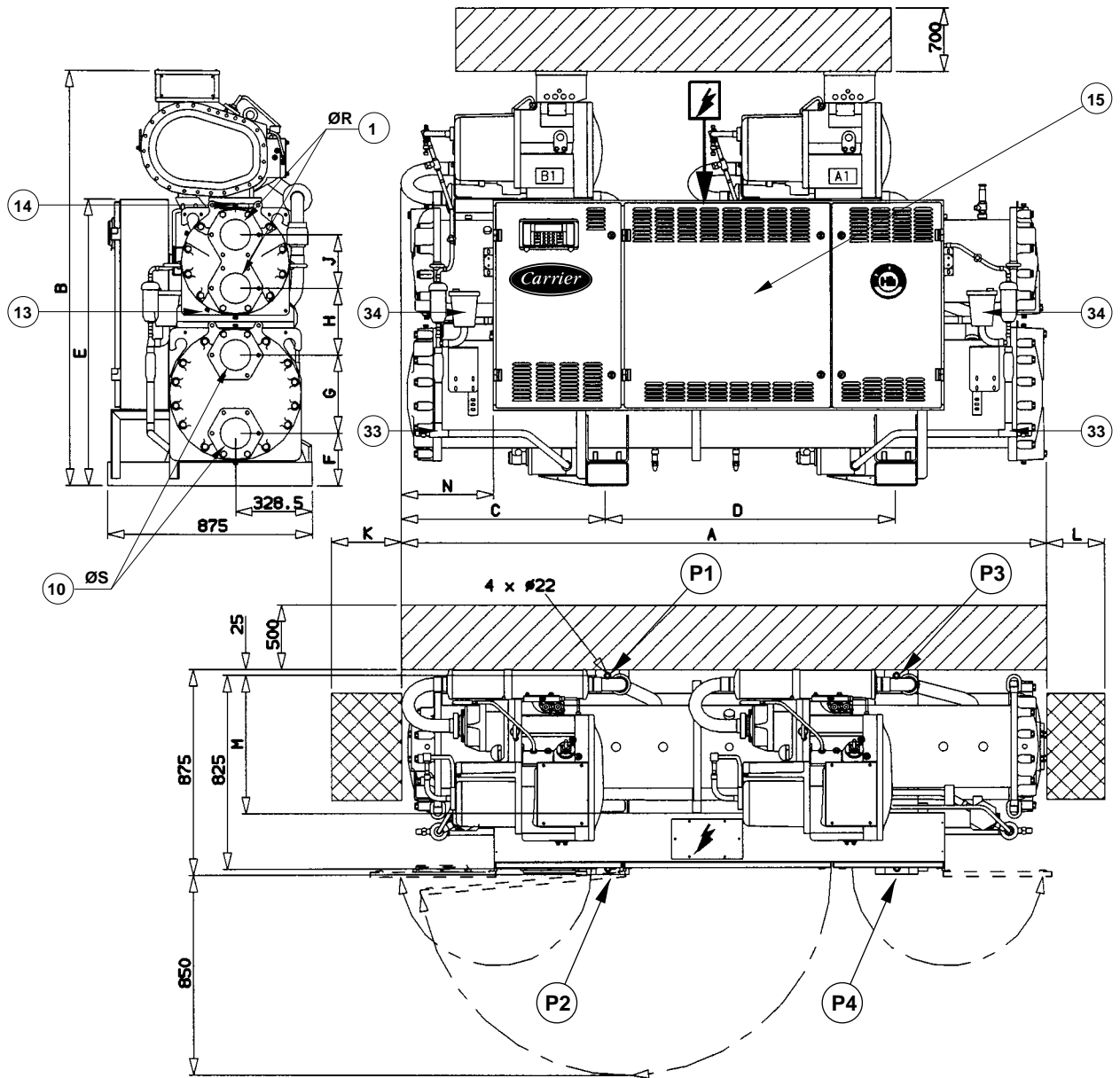

## 30HXC 075-185



30HXC	A	B	C	D	E	F	G	H	J	K	L	M	N	ØR	ØS
075-095	2730	1775	875	1217	1220	222.5	332	268.3	265.4	2360	1000	593	279	114.3	139.7
105	2730	1825	875	1217	1220	222.5	332	276.5	300	2360	1000	593	279	139.7	139.7
115-145	3535	1775	1035	1635	1220	222.5	332	286	230	3220	1000	593	734	19.7	139.7
160-170	3550	1900	1195	1635	1328	306	257	340	300	3220	1000	620	804	139.7	168.3
185	3550	1900	1195	1635	1328	306	257	360	260	3220	1000	620	804	168.3	168.3

30HXC	Weight distribution at the four mounting holes (kg)				Total operating weight (kg)
	P1	P2	P3	P4	
075	703	613	634	553	2503
085	707	617	637	557	2518
095	719	627	647	567	2560
105	767	670	691	603	2731
115	795	695	716	627	2833
125	807	705	726	634	2872
135	830	726	746	654	2956
145	835	730	750	656	2971
160	922	808	818	735	3283
170	936	848	848	771	3403
185	968	876	876	797	3517

### Legend :

-  Services clearances required
-  Space required to remove cooler and condenser tubes
-  Electrical supply entry

NOTE : Refer to certified dimensional drawings 99DI 075HX when designing an installation.

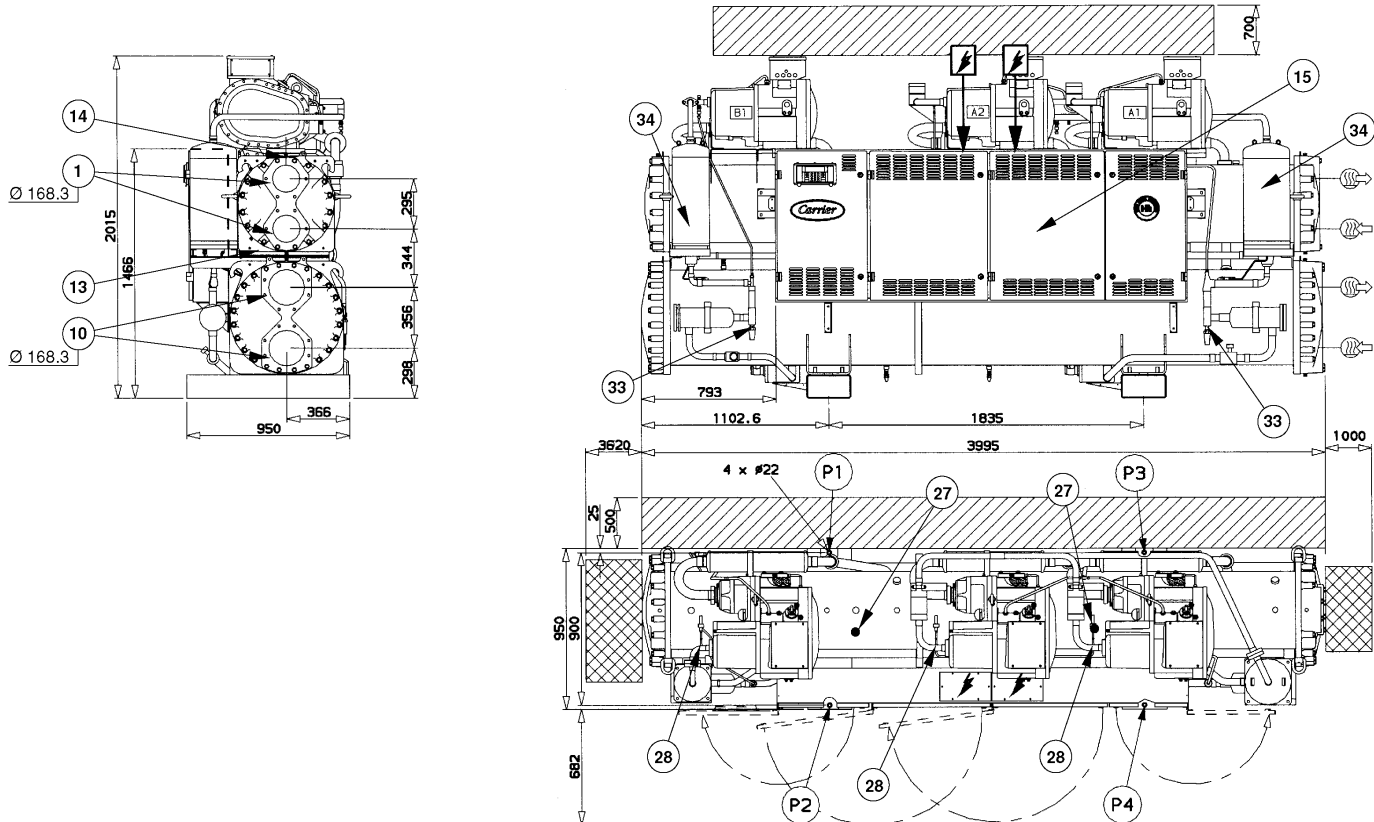

**DIMENSIONS, CLEARANCES, WEIGHT DISTRIBUTION (CONT.)**

**30HXC 215-280**



30HXC	Weight distribution at the four mounting holes (kg)				Total operating weight (kg)
	P1	P2	P3	P4	PT
215	1319	1127	1232	1052	4730
250	1348	1207	1288	1154	4996
265	1354	1213	1295	1159	5021
280	1361	1218	1302	1165	5046

**Legend :**

-  Services clearances required
-  Space required to remove cooler and condenser tubes
-  Electrical supply entry



NOTE : Refer to certified dimensional drawings 99DI 215HX when designing an installation.

**DIMENSIONS, CLEARANCES, WEIGHT DISTRIBUTION (CONT.)**

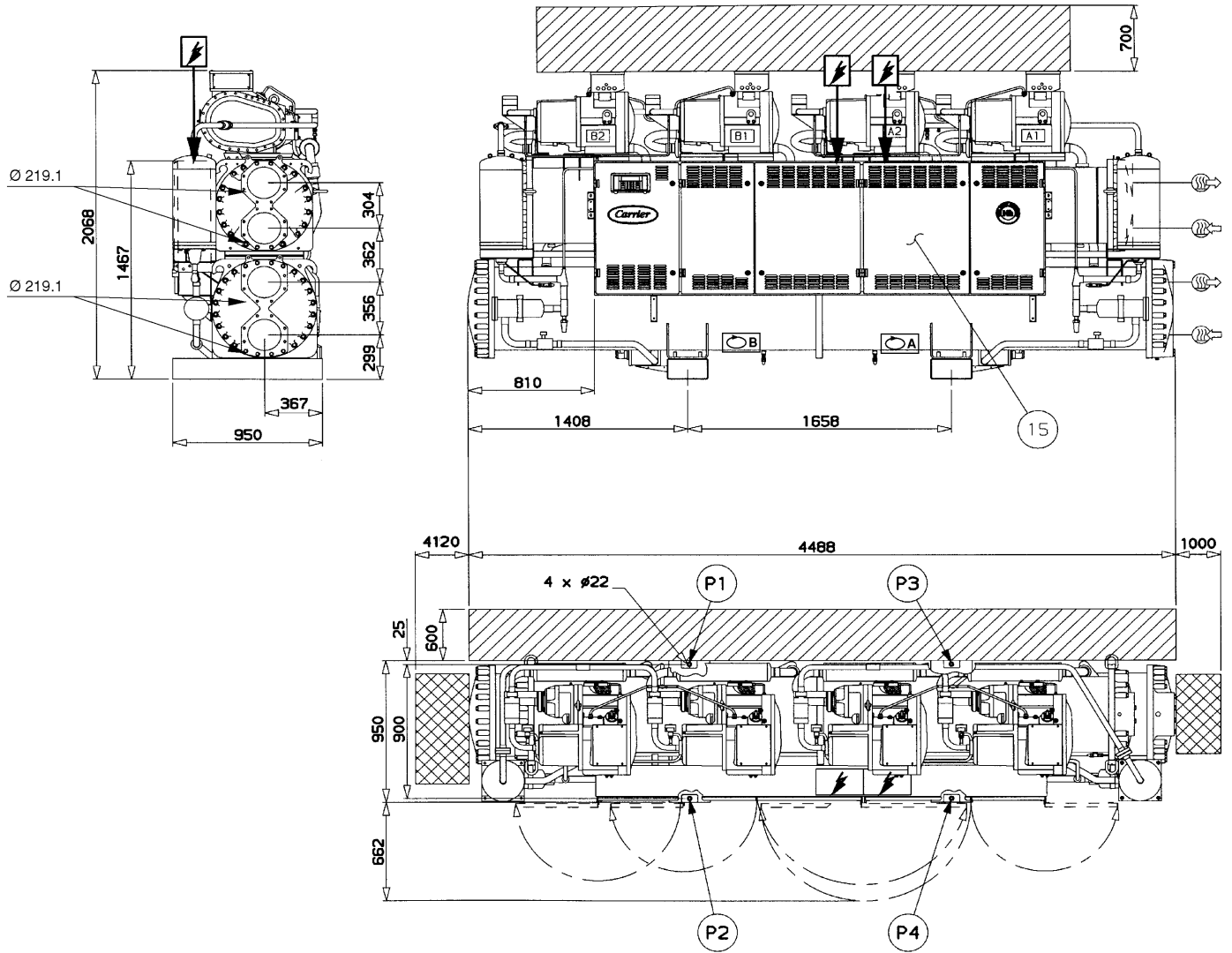
**30HXC 300-370**



30HXC	Weight distribution at the four mounting holes (kg)				Total operating weight (kg)
	P1	P2	P3	P4	
300	1573	1444	1498	1375	5890
315	1625	1479	1552	1413	6070
340	1647	1499	1555	1414	6115
370	1659	1507	1571	1428	6165

- Legend :**
-  Services clearances required
  -  Space required to remove cooler and condenser tubes
  -  Electrical supply entry

NOTE : Refer to certified dimensional drawings 99DI 300HX when designing an installation.

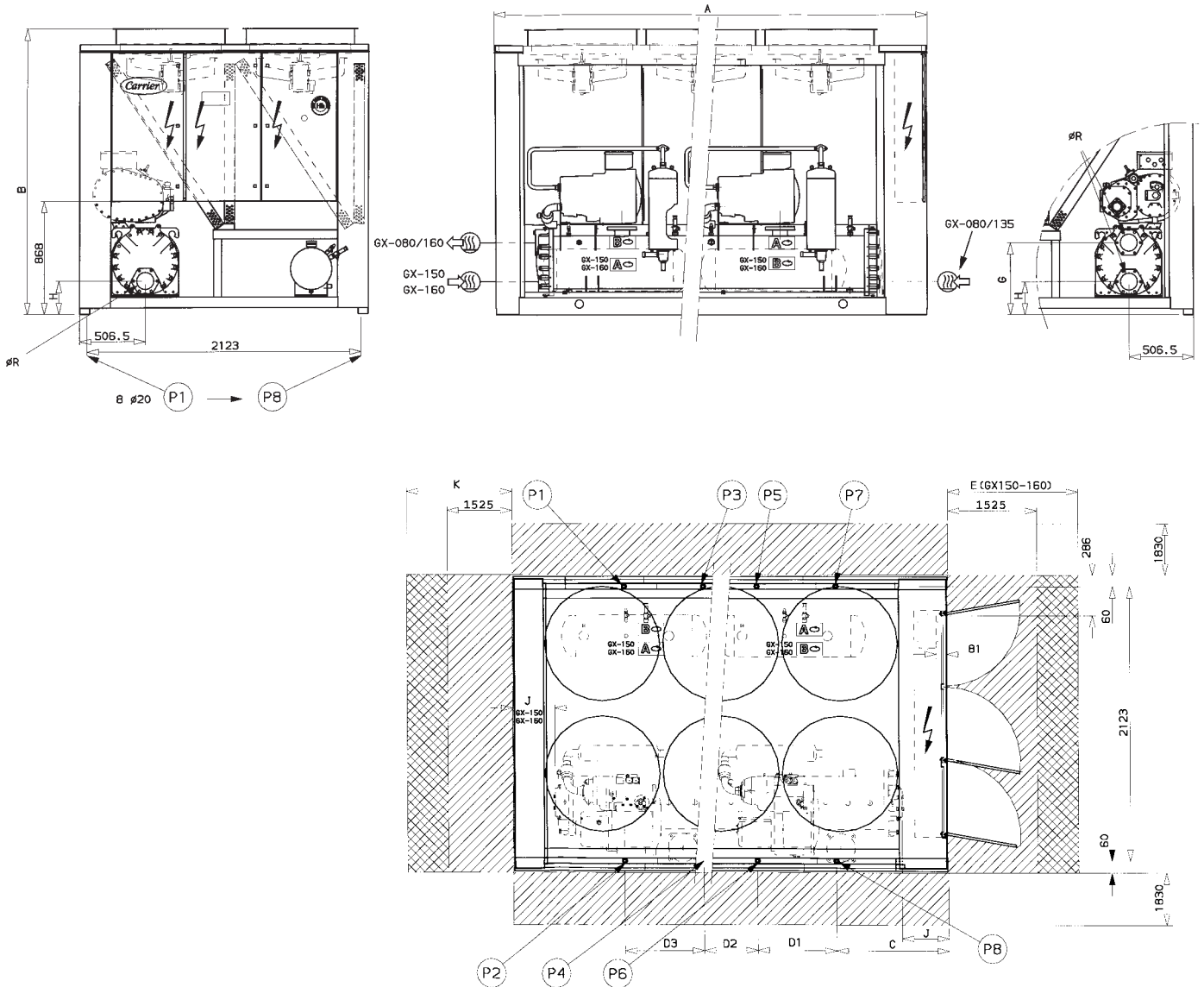

**DIMENSIONS, CLEARANCES, WEIGHT DISTRIBUTION (CONT.)**

**30GX 080-160**



30GX	A	B	C	D	D2	D3	E	G	H	J	K	R
080-090	2882	2200	627	609.6	409.6	609.6	N/A	515	249	128	2300	114.3
105	2882	2200	627	609.6	409.6	609.6	N/A	558	256	120	2300	139.7
115-135	3340	2200	856	609.6	409.6	609.6	N/A	558	256	348.5	2100	139.7
150	4254	2200	627	658.3	1170.5	658.3	2800	497	267	283	N/A	139.7
160	4254	2200	627	658.3	1170.5	658.3	2800	497	267	275	N/A	139.7

30GX	Weight distribution at the eight mounting holes (kg)								Total operating weight (kg)
	P1	P2	P3	P4	P5	P6	P7	P8	
080	456	583	252	286	252	286	587	708	3410
090	456	583	252	288	252	288	587	712	3420
105	456	645	252	348	252	348	587	770	3658
115	456	689	252	390	252	390	587	813	3829
125	456	700	252	403	252	403	587	824	3877
135	456	703	252	406	252	406	587	827	3889
150	268	166	463	630	403	615	655	990	4189
160	268	166	463	646	403	631	655	1007	4239

- Notes :**
- Unit must have clearances for air flow as follows :  
TOP : do not restrict in any way  
 End and side space required (from solid surface)
  - In case of multiple chillers (up to four units), the respective clearance between them should be increased from 1830 to 2000 mm for the side space requirement.
  - Unit must have clearances for cooler tube removal as follows :  
 Additional space required to remove cooler tubes
-  Electrical box

**Multiple chiller installation (see note 2 and sketch on page 9)**

NOTE : Refer to certified dimensional drawings 99DI 080GX when designing an installation.



**DIMENSIONS, CLEARANCES, WEIGHT DISTRIBUTION (CONT.)**

**30GX 175**

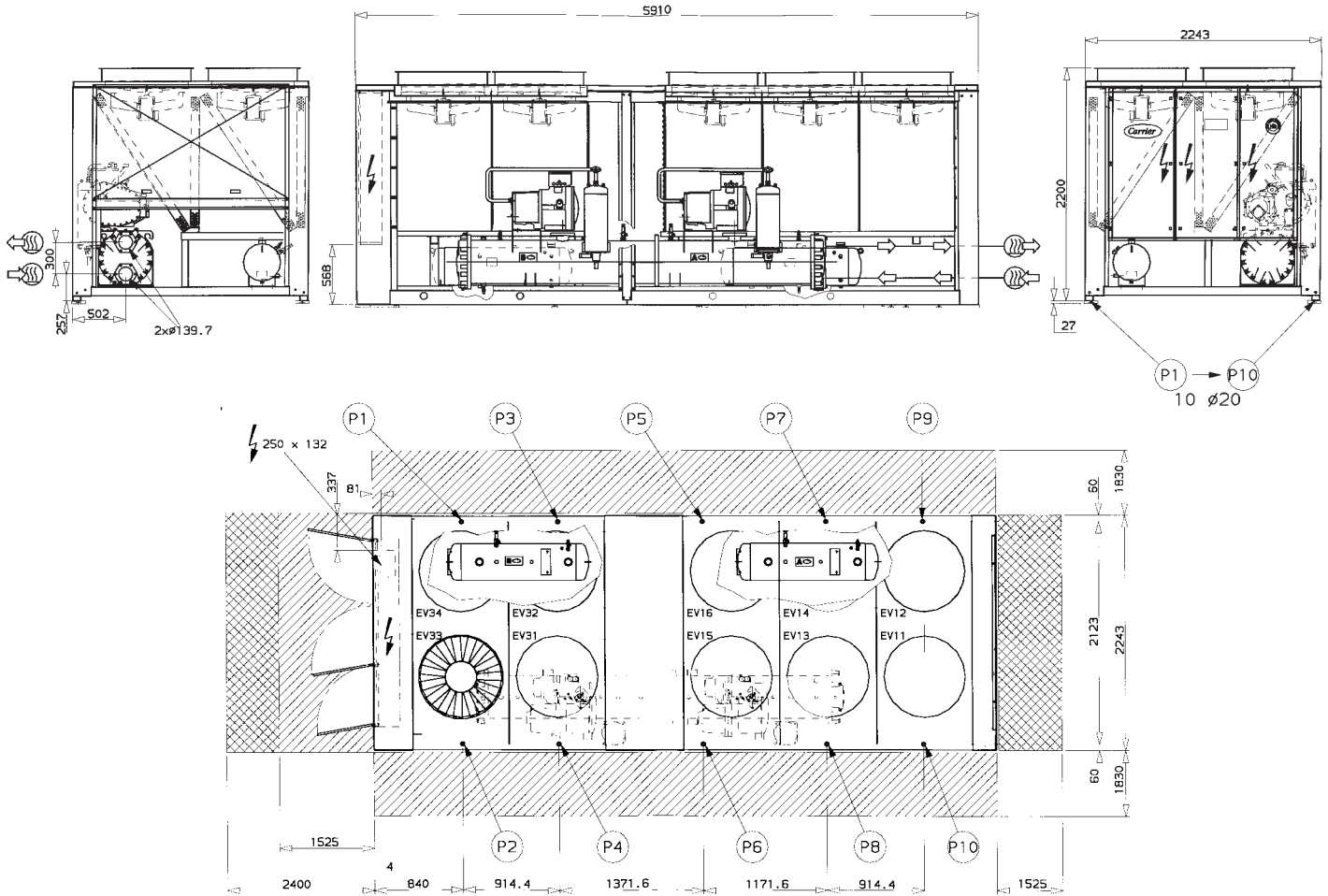

Weight distribution at the ten mounting holes (kg)											Total operating weight (kg)
30GX	P1	P2	P3	P4	P5	P6	P7	P8	P9	P10	PT
175	506	323	322	635	467	687	527	702	321	181	4671

**Multiple chiller installation (see note 2)**

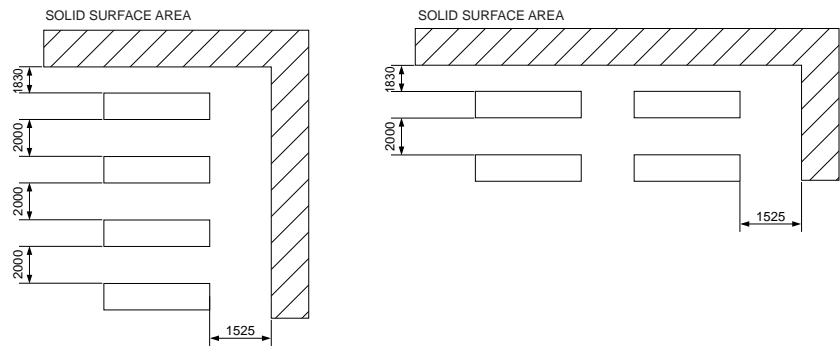

**Notes :**

- Unit must have clearances for air flow as follows :  
Top : do not restrict in any way

End and Side space required (from solid surface)

- In case of multiple chillers (up to four units), the respective clearance between them should be increased from 1830 to 2000 mm for the side space requirement.

- Unit must have clearances for cooler tube removal as follows :

Additional space required to remove cooler tubes

Electrical box

NOTE : Refer to certified dimensional drawings 99DI 175GX when designing an installation.

**DIMENSIONS, CLEARANCES, WEIGHT DISTRIBUTION (CONT.)**

**30GX 205-265**

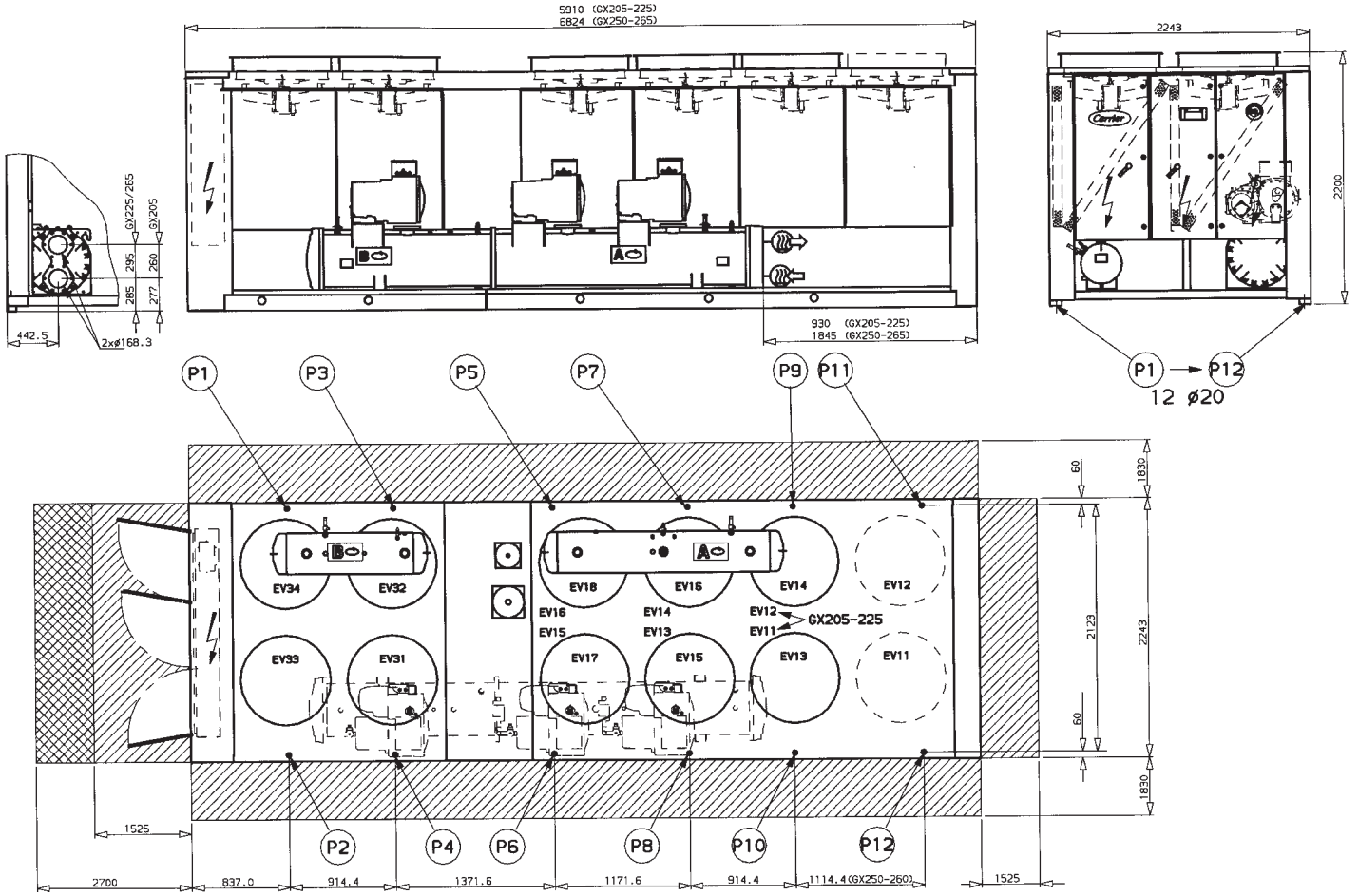

30GX	Weight distribution at the twelve mounting holes (kg)												Total operating weight (kg)
	P1	P2	P3	P4	P5	P6	P7	P8	P9	P10	P11	P12	
205	573	321	453	857	575	902	655	923	367	184	-	-	5810
225	573	370	453	904	575	950	655	970	367	231	-	-	6048
250	593	330	453	860	575	912	655	920	367	195	250	200	6310
265	593	382	453	906	575	962	655	970	367	243	250	200	6556

**Multiple chiller installation (see note 2)**

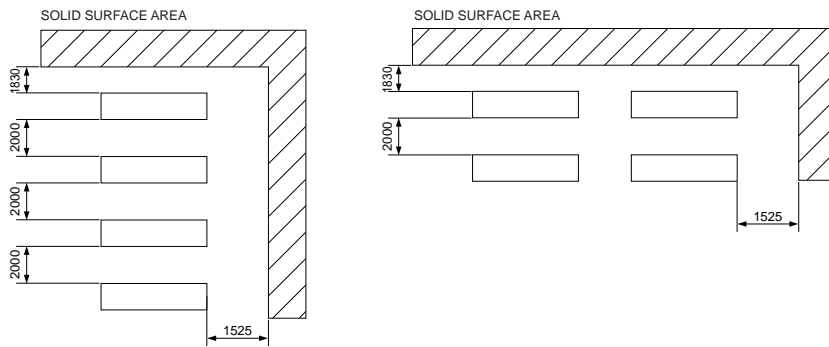

**Notes :**

1. Unit must have clearances for air flow as follows :  
Top : do not restrict in any way

 End and Side space required (from solid surface)

2. In case of multiple chillers (up to four units), the respective clearance between them should be increased from 1830 to 2000 mm for the side space requirement.

3. Unit must have clearances for cooler tube removal as follows :

 Additional space required to remove cooler tubes

 Electrical box

NOTE : Refer to certified dimensional drawings 99DI 205GX when designing an installation.

# DIMENSIONS, CLEARANCES, WEIGHT DISTRIBUTION (CONT.)

## 30GX 280-350

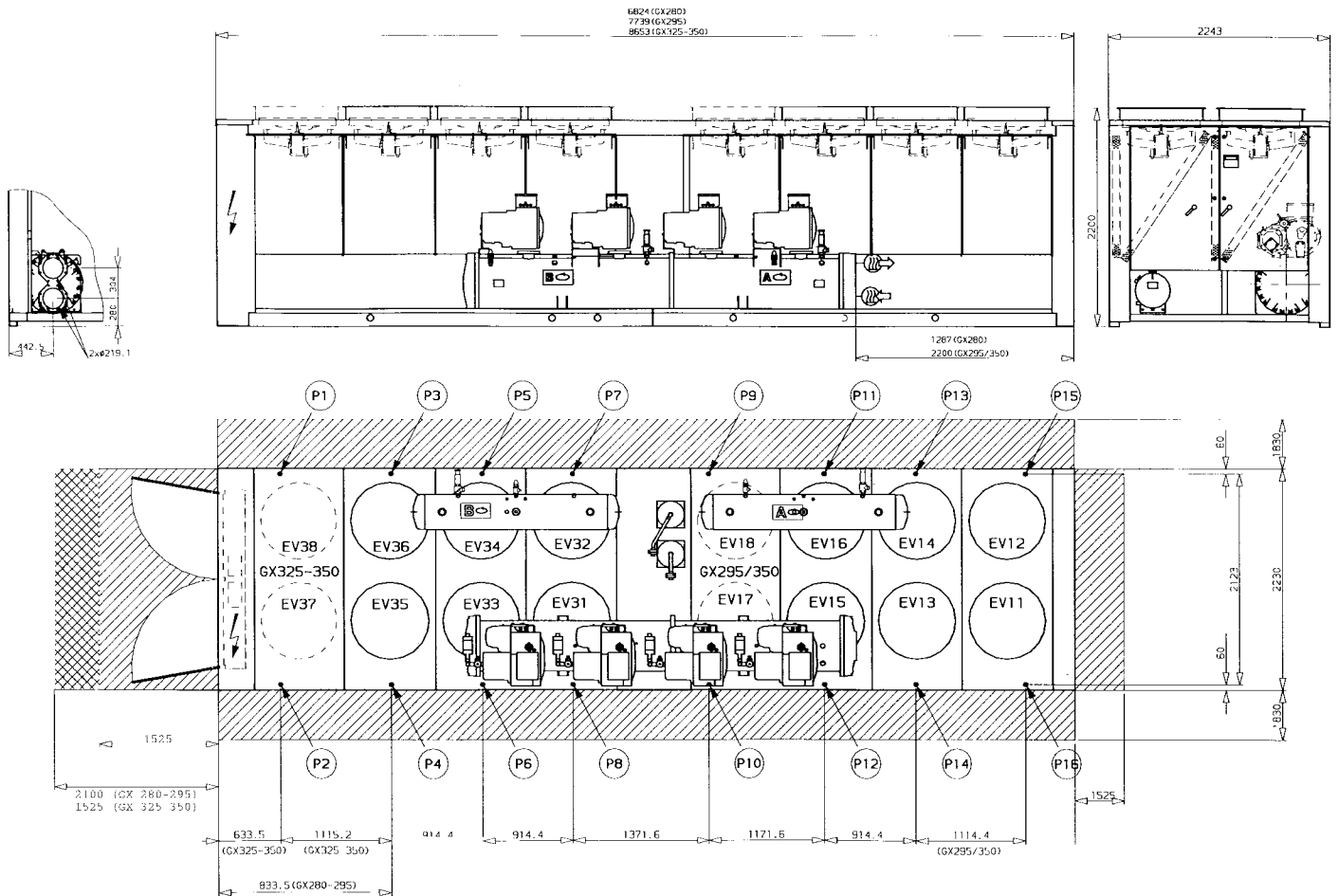

30GX	Weight distribution at the sixteen mounting holes (kg)																Total operating weight (kg)
	P1	P2	P3	P4	P5	P6	P7	P8	P9	P10	P11	P12	P13	P14	P15	P16	
280	-	-	400	300	650	900	650	900	550	900	650	900	300	203	-	-	7303
295	-	-	400	300	650	936	650	930	550	900	650	900	200	150	150	130	7496
325	300	200	300	200	640	920	630	920	533	920	640	920	200	150	150	130	7753
350	300	200	300	200	650	930	650	930	550	930	650	930	250	150	150	132	7852

### Multiple chiller installation (see note 2)

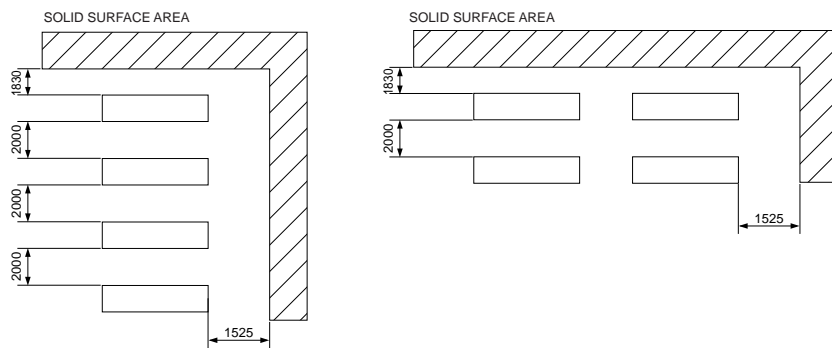

#### Notes :

1. Unit must have clearances for air flow as follows :  
Top : do not restrict in any way

 End and Side space required (from solid surface)

2. In case of multiple chillers (up to four units), the respective clearance between them should be increased from 1830 to 2000 mm for the side space requirement.

3. Unit must have clearances for cooler tube removal as follows :

 Additional space required to remove cooler tubes



Electrical box

NOTE : Refer to certified dimensional drawings 99DI 280GX when designing an installation.

# MAIN COMPONENTS LOCATION



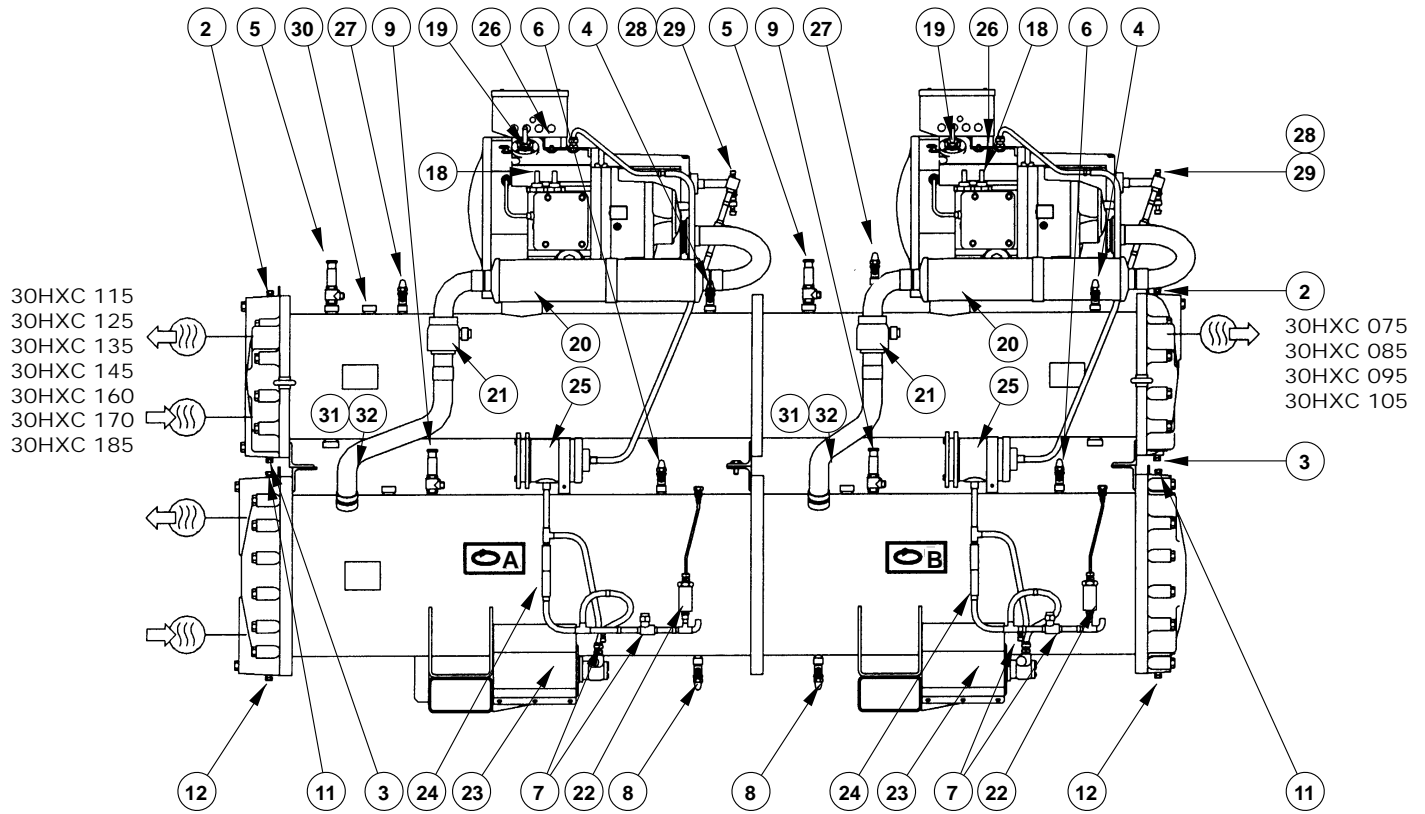

## 30HXC 075-185



ITEM	DESIGNATION
1	Cooler water inlet and outlet
2	Cooler 3/8" NPT air vent
3	Cooler 3/8" NPT water drain
4	Refrigerant charging valve
5	Cooler safety relief valve
6	Oil charging valve
7	Closing valve and oil drain
8	Refrigerant recovery valve
9	Condenser safety relief valve
10	Condenser inlet and outlet
11	Condenser 3/8" NPT air vent
12	Condenser 3/8" NPT water drain
13	Cooler entering fluid thermistor
14	Cooler leaving fluid thermistor
15	Electrical box
16	Power terminal block (see field power supply)
17	Main disconnect switch option (see field power supply)

ITEM	DESIGNATION
18	Capacity loaders
19	Oil solenoid valve
20	External muffler
21	Discharge valve
22	Oil level switch
23	Prelube oil pump
24	Oil check valve
25	Oil prefilter
26	Compressor oil filter housing
27	Cooler liquid level sensor
28	Motor cooling valve
29	Economizer pressure transducer
30	Suction pressure transducer
31	Discharge pressure transducer
32	Discharge temperature thermistor
33	Liquid valve
34	Electronic expansion valve

### Legend:

-  Circuit A
-  Circuit B
-  Water inlet (flanges supplied)
-  Water outlet (flanges supplied)

# MAIN COMPONENTS LOCATION (CONT.)

## 30HXC 215-280

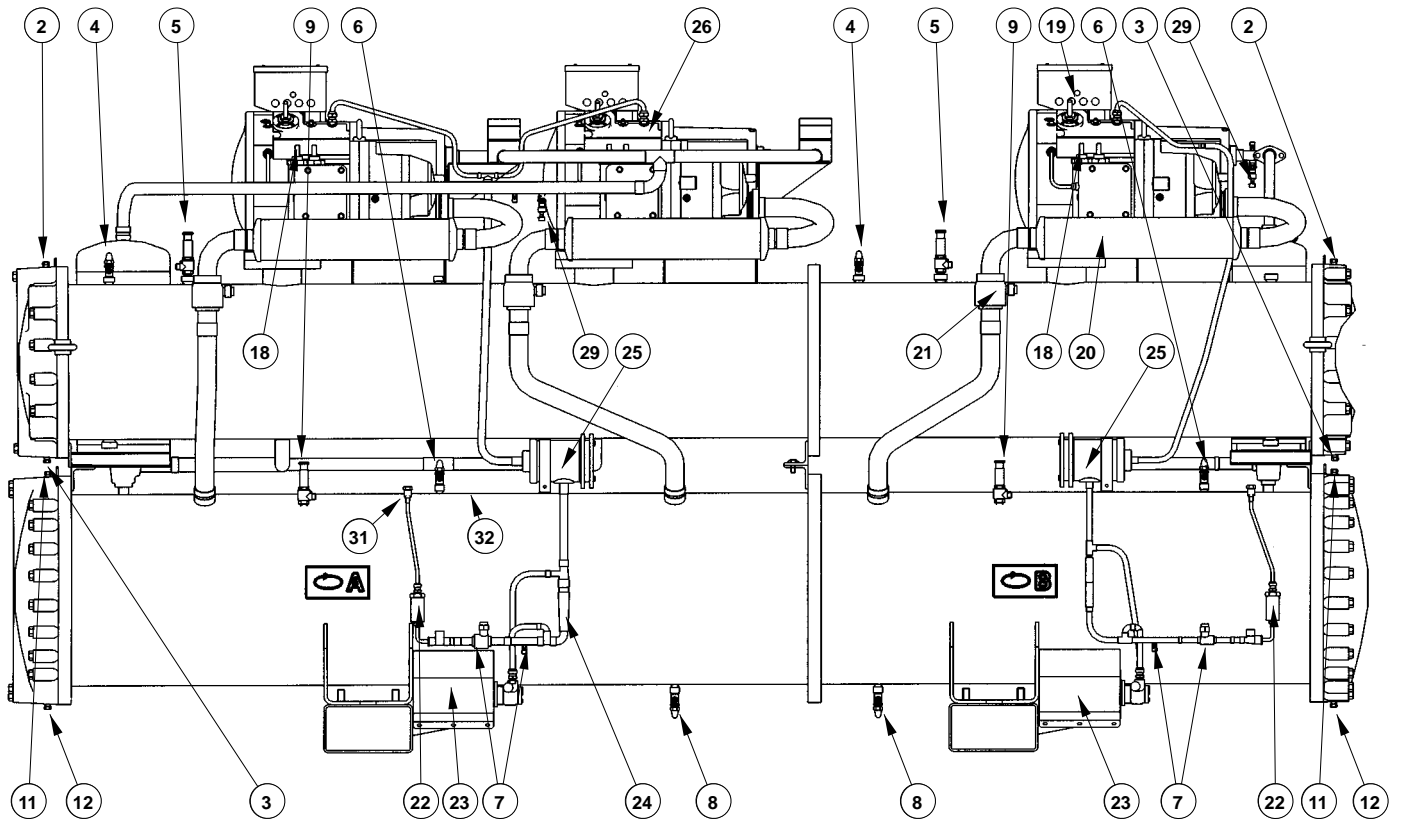

ITEM	DESIGNATION
1	Cooler water inlet and outlet
2	Cooler 3/8" NPT air vent
3	Cooler 3/8" NPT water drain
4	Refrigerant charging valve
5	Cooler safety relief valve
6	Oil charging valve
7	Closing valve and oil drain
8	Refrigerant recovery valve
9	Condenser safety relief valve
10	Condenser inlet and outlet
11	Condenser 3/8" NPT air vent
12	Condenser 3/8" NPT water drain
13	Cooler entering fluid thermistor
14	Cooler leaving fluid thermistor
15	Electrical box
16	Power terminal block (see field power supply)
17	Main disconnect switch option (see field power supply)

ITEM	DESIGNATION
18	Capacity loaders
19	Oil solenoid valve
20	External muffler
21	Discharge valve
22	Oil level switch
23	Prelube oil pump
24	Oil check valve
25	Oil prefilter
26	Compressor oil filter housing
27	Cooler liquid level sensor
28	Motor cooling valve
29	Economizer pressure transducer
30	Suction pressure transducer
31	Discharge pressure transducer
32	Discharge temperature thermistor
33	Liquid valve
34	Economizer

**Legend :**

 Circuit A

 Circuit B

**PHYSICAL DATA**

**30HXC**

30HXC		075	085	095	105	115	125	135	145	160	170	185
<b>Nominal gross cooling capacity*</b>	kW	268	295	346	373	404	439	485	519	550	593	639
<b>Operating weight**</b>	kg	2503	2518	2560	2731	2833	2872	2956	2971	3283	3403	3517
<b>Refrigerant</b>		HFC-134a										
<b>Refrigerant charge CKT A/CKT B</b>	kg	See unit nameplate										
<b>Oil</b>		Polyolester oil CARRIER SPEC : PP 47-32										
<b>Oil charge CKT A/CKT B</b>	l	20/20	20/20	20/20	20/20	20/20	20/20	20/20	20/20	20/20	20/20	20/20
<b>Compressor</b>		Semi-hermetic twin screw										
Ckt A (nominal capacity compressor A1)	Tons	39	46	56	66	66	66	80	80	80	66	80
Ckt B (nominal capacity compressor B1)	Tons	39	39	39	39	46	56	56	66	80	80	80
Economizer		No	No	No	No	No	No	No	No	No	Yes	Yes
Capacity steps	No.	6	6	6	6	6	6	6	6	6	6	6
Minimum capacity	%	20	20	20	20	20	20	20	20	20	20	20
<b>Cooler</b>		One shell & tube cooler with enhanced copper tubes										
Net water volume	l	65	65	73	87	81	81	91	91	109	109	127
Refrigerant circuits	No.	2	2	2	2	2	2	2	2	2	2	2
Water connection		Factory supplied flat flange to be site welded										
Inlet & outlet diameter	inches	4	4	4	5	5	5	5	5	5	5	6
Air vent diameter (on water box)	inches	3/8" NPT										
Water drain diameter (on water box)	inches	3/8" NPT										
Maximum operating pressure water side	kPa	1000										
<b>Condenser</b>		One shell & tube condenser with enhanced copper tubes										
Net water volume	l	67	67	67	74	89	96	110	110	132	136	145
Refrigerant circuits	No.	2	2	2	2	2	2	2	2	2	2	2
Water connection		Factory supplied flat flange to be site welded										
Inlet & outlet diameter	inches	5	5	5	5	5	5	5	5	6	6	6
Air vent diameter (on water box)	inches	3/8" NPT										
Water drain diameter (on water box)	inches	3/8" NPT										
Maximum operating pressure water side	kPa	1000										

30HXC		215	250	265	280	300	315	340	370			
<b>Nominal gross cooling capacity*</b>	kW	757	879	921	965	1054	1140	1195	1290			
<b>Operating weight**</b>	kg	4730	4996	5021	5046	5890	6070	6115	6165			
<b>Refrigerant</b>		HFC-134a										
<b>Refrigerant charge CKT A/CKT B</b>	kg	See unit nameplate										
<b>Oil</b>		Polyolester oil CARRIER SPEC : PP 47-32										
<b>Oil charge CKT A/CKT B</b>	l	40/20	40/20	40/20	40/20	40/40	40/40	40/40	40/40			
<b>Compressor</b>		Semi-hermetic twin screw										
Ckt A (nominal capacity compressor A1)	Tons	80/56	50/56	50/66	80/80	56/66	56/80	66/80	80/80			
Ckt B (nominal capacity compressor B1)	Tons	80	80	80	80	66/66	56/80	66/80	80/80			
Economizer		No	Yes	Yes	Yes	Yes	Yes	Yes	Yes			
Capacity steps	No.	8	8	8	8	10	10	10	10			
Minimum capacity	%	15	15	15	15	10	10	10	10			
<b>Cooler</b>		One shell & tube cooler with enhanced copper tubes										
Net water volume	l	165	181	181	181	203	229	229	229			
Refrigerant circuits	No.	2	2	2	2	2	2	2	2			
Water connection		Factory supplied flat flange to be site welded										
Inlet & outlet diameter	inches	6	6	6	6	8	8	8	8			
Air vent diameter (on water box)	inches	3/8" NPT										
Water drain diameter (on water box)	inches	3/8" NPT										
Maximum operating pressure water side	kPa	1000										
<b>Condenser</b>		One shell & tube condenser with enhanced copper tubes										
Net water volume	l	208	208	208	208	231	251	251	251			
Refrigerant circuits	No.	2	2	2	2	2	2	2	2			
Water connection		Factory supplied flat flange to be site welded										
Inlet & outlet diameter	inches	6	6	6	6	8	8	8	8			
Air vent diameter (on water box)	inches	3/8" NPT										
Water drain diameter (on water box)	inches	3/8" NPT										
Maximum operating pressure water side	kPa	1000										

**Legend :**

- \* Eurovent conditions :  
Evaporator entering/leaving water temperature 12°C and 7°C,  
Condenser entering/leaving water temperature 30°C and 35°C.
- \*\* Weight includes weight of water or brine and refrigerant.

## ELECTRICAL DATA

### 30HXC

30HXC		075	085	095	105	115	125	135	145	160	170	185
<b>Mains power supply</b>												
Nominal voltage	V-ph-Hz	400-3-50										
Voltage range	%	± 10										
Control circuit voltage*	V-ph-Hz	230-1-50										
Nominal unit power input**	kW	62.1	68	80.5	86.4	90.6	98.4	108.7	117.9	124	133	144.3
Nominal operating current**	A	87	96	122	133	139	165	178	189	203	206	239
Maximum operating current***	A	142	157	175	195	210	228	255	275	302	300	330
Maximum starting current Across the line start****	A	415	494	577	676	691	709	819	839	866	992	1021
Optional star delta start****	A	180	205	231	262	277	295	330	350	377	406	435

30HXC		215	250	265	280	300	315	340	370
<b>Mains power supply</b>									
Nominal voltage	V-ph-Hz	400-3-50							
Voltage range	%	± 10							
Control circuit voltage*	V-ph-Hz	230-1-50							
Nominal unit power input**	kW	171.8	192.3	204	216.3	229.2	246.5	263.1	289.2
Nominal operating current**	A	308.0	327.9	342.5	360.3	398.5	416.2	443.3	480.9
Maximum operating current***	A								
Circuit A		255	278	300	330	248	278	300	330
Circuit B		151	165	165	165	271	278	300	330
Maximum starting current Across the line start****	A	970	1134	1156	1186	1099	1247	1292	1350
Optional star delta start****	A	481	548	570	600	610	661	706	764

**Legend :**

- \* Control power circuit is supplied through factory installed transformer
- \*\* Unit power input kW and current drawn at cooler entering/leaving temperature 12°C/7°C, condenser entering/leaving temperature 30°C/35°C and at 400 Volts nominal voltage
- \*\*\* Maximum current drawn by compressors at full load and at minimum voltage 360 Volts
- \*\*\*\* Maximum instantaneous starting current (maximum operating current of the smallest compressor + locked rotor amps of the largest compressor)

### Compressor

PART NUMBER	Tons	LRA (Y)	LRA (Delta)	MHA
O6NW 1146 S7 N	39	109	344	71
O6NW 1174 S7 N	46	134	423	86
O6NW 1209 S7 N	56	160	506	104
O6NW 1250 S7 N	66	191	605	124
O6NW 1300 S5 N	80	226	715	151
O6NW 1209 S7 E	56	191	605	113
O6NW 1250 S7 E	66	226	715	136
O6NW 1300 S5 E	80	270	856	165

**Legend :**

- LRA (Y)** Locked Rotor Amps with optional star delta start
- LRA (Delta)** Locked Rotor Amps with standard across the line start
- MHA** Compressor Must Hold Amps (Maximum Operating Current at 360 V)
- O6NW** Water-cooled condensing compressor
- N** Non Economized compressor
- E** Economized compressor

## PHYSICAL DATA

### 30GX

30GX		080	090	105	115	125	135	150	160	175
<b>Nominal gross cooling capacity*</b>	kW	262	290	330	373	405	438	484	526	576
<b>Operating weight</b>	kg	3410	3420	3658	3829	3877	3889	4189	4239	4671
<b>Refrigerant</b>		HFC-134a								
<b>Refrigerant charge CKT A/CKT B</b>	kg	See unit nameplate								
<b>Compressor</b>		Semi-hermetic twin screw								
Ckt A, nominal capacity per compressor	Tons	46	56	56	66	66	66	80	80	80
Ckt B, nominal capacity per compressor	Tons	39	39	39	39	46	56	56	66	80
Economizer		No	No	Yes	Yes	Yes	Yes	Yes	Yes	Yes
Capacity steps	No.	6	6	6	6	6	6	6	6	6
Minimum capacity	%	20	20	20	20	20	20	20	20	20
<b>Cooler</b>										
Net water volume	l	73	73	87	87	101	101	91	109	109
Refrigerant circuits	No.	2	2	2	2	2	2	2	2	2
Water connection		Customized flat flange supplied to be welded on site								
Inlet & outlet diameter	inches	4	4	5	5	5	5	5	5	5
Air vent diameter (on water box)	inches	3/8" NPT								
Water drain diameter (on water box)	inches	3/8" NPT								
Maximum operating pressure water side	kPa	1000								
<b>Condenser fans</b>		Airfoil blades								
Number		4	4	4	6	6	6	8	8	10
Total air flow	l/s	20518	20518	20518	29505	29505	28268	37714	37714	48370
Speed	rps	15.8	15.8	15.8	15.8	15.8	15.8	15.8	15.8	15.8
<b>Condenser coils</b>		Copper tubes & aluminium fins								

30GX		205	225	250	265	280	295	325	350	
<b>Nominal gross cooling capacity*</b>	kW	666	745	825	854	918	977	1066	1158	
<b>Operating weight</b>	kg	5810	6048	6310	6556	7303	7496	7753	7852	
<b>Refrigerant</b>		HFC-134a								
<b>Refrigerant charge CKT A/CKT B</b>	kg	See unit nameplate								
<b>Compressor</b>		Semi-hermetic twin screw								
Ckt A, nominal capacity per compressor A1/A2	Tons	39/80	46/80	66/80	80/80	66/66	56/80	66/80	80/80	
Ckt B, nominal capacity per compressor B1/B2	Tons	66	80	80	80	56/66	56/80	66/80	80/80	
Economizer		Yes	Yes	Yes	Yes	Yes	Yes	Yes	Yes	
Capacity steps	No.	8	8	8	8	10	10	10	10	
Minimum capacity	%	15	15	15	15	10	10	10	10	
<b>Cooler</b>										
Net water volume	l	140	165	181	181	203	203	229	229	
Refrigerant circuits	No.	2	2	2	2	2	2	2	2	
Water connection		Customized flat flange supplied to be welded on site								
Inlet & outlet diameter	inches	6	6	6	6	8	8	8	8	
Air vent diameter (on water box)	inches	3/8" NPT								
Water drain diameter (on water box)	inches	3/8" NPT								
Maximum operating pressure water side	kPa	1000								
<b>Condenser fans</b>		Airfoil blades								
Number		10	10	12	12	12	14	16	16	
Total air flow	l/s	47142	47142	56571	56571	56571	66000	75428	75428	
Speed	rps	15.8	15.8	15.8	15.8	15.8	15.8	15.8	15.8	
<b>Condenser coils</b>		Copper tubes & aluminium fins								

**Legend :**

\* Eurovent conditions :

Cooler entering/leaving water temperature : 12°C and 7°C,  
Condenser entering air temperature : 35°C.



## ELECTRICAL DATA

### 30GX

30GX		080	090	105	115	125	135	150	160	175
<b>Main power supply</b>										
Nominal voltage	V-ph-Hz	400-3-50								
Voltage range	%	± 10								
<b>Control circuit supply*</b>										
Nominal unit power input**	kW	94,2	108,9	124	137,2	151,2	167	178	200,4	211,5
Nominal operating current**	A	183	200	216	238	256	271	299	325	353
Maximum operating current***	A	230	256	286	322	347	375	424	461	510
Maximum starting current Across the line start****	A	829	970	1087	1358	1383	1410	1454	1491	1545
Optional star delta start****	A	340	384	430	519	544	571	589	626	680

30GX		205	225	250	265	280	295	325	350
<b>Main power supply</b>									
Nominal voltage	V-ph-Hz	400-3-50							
Voltage range	%	± 10							
<b>Control circuit supply*</b>									
Nominal unit power input**	kW	243,2	289,1	307,9	327,7	352,5	368,6	397,7	459,9
Nominal operating current**	A	415	476	505	547	571	612	652	736
Maximum operating current***	A								
Circuit A		387	412	481	530	426	444	481	530
Circuit B		216	265	265	265	390	439	481	530
Maximum starting current Across the line start****	A	1612	1687	1756	1805	1837	1894	1971	2070
Optional star delta start****	A	747	822	891	940	N/A	N/A	N/A	N/A

**Legend :**

\* Control power circuit is supplied through factory installed transformer

\*\* Unit power input kW and current drawn at cooler entering/leaving temperature 12°C/7°C, condenser entering air temperature 35°C and at 400 Volts nominal voltage

\*\*\* Maximum current drawn by compressors and fans at full load and at minimum voltage 360 Volts

\*\*\*\* Maximum instantaneous starting current (maximum operating current of the smallest compressor + locked rotor amps of the largest compressor)

N/A - not available

### Compressor

PART NUMBER	Tons	LRA (Y)	LRA (Delta)	MHA
06NA 1146 S7 N	39	191	605	104
06NA 1174 S7 N	46	226	715	126
06NA 1209 S7 N	56	270	856	152
06NA 1146 S7 E	39	226	715	117
06NA 1174 S7 E	46	270	856	142
06NA 1209 S7 E	56	303	960	169
06NA 1250 S7 E	66	387	1226	206
06NA 1300 S5 E	80	400	1265	255

**Legend :**

**LRA (Y)** Locked Rotor Amps with optional star delta start

**LRA (Delta)** Locked Rotor Amps with standard across the line start

**MHA** Compressor Must Hold Amps (Maximum Operating Current at 360 V)

**06NA** Air-cooled condensing compressor

**N** Non Economized compressor

**E** Economized compressor

## APPLICATION DATA

### Unit operating range

Cooler		Minimum	Maximum
Cooler entering water temperature	°C	6.8*	21
Cooler leaving water temperature	°C	4**	15
Condenser (water-cooled)		Minimum	Maximum
Condenser entering water temperature	°C	20***	42
Condenser leaving water temperature	°C	23	45
Condenser (air-cooled)		Minimum	Maximum
Outdoor ambient operating temperature	°C	0	45

#### Notes :

\* For application requiring operation at less than 6.8°C, contact Carrier s.a. for unit selection using the Carrier electronic catalog.

\*\* For application requiring operation at less than 4°C, the units require the use of antifreeze.

\*\*\* Water-cooled units (30HXC) operating at less than 20°C for condenser entering water require the use of head pressure control with analogue water valves (see head pressure control paragraph).

### Minimum chilled water flow

The minimum chilled water flow (maximum chilled water temperature difference) is shown in the table below. If the flow is less than this (a high temperature difference) three solutions are possible :

- Check for availability of a non-standard evaporator (plus one pass) which will allow a lower water flow rate (contact factory).
- The evaporator flow can be recirculated as shown in the diagram. The temperature of the mixture leaving the evaporator must never be less than 2.8 K lower than the chilled water entering temperature.
- Link several chillers in series with each making a contribution to the total temperature difference.

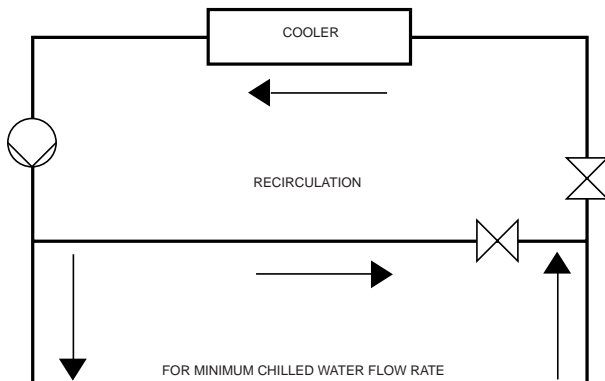

### Maximum chilled water flow

The maximum chilled water flow ( $> 0.09$  l/s per kW or  $< 2.8$  K temperature difference) is limited by the maximum permitted pressure drop in the evaporator. It is provided in the following table :

- Select a non-standard evaporator with one water pass less which will allow a higher maximum water flow rate.
- Bypass the evaporator as shown in the diagram to obtain a higher temperature difference with a lower evaporator flow rate.

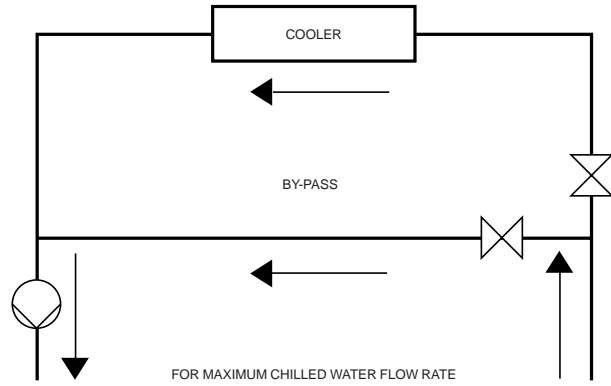

## Cooler flow rate (l/s)

30HXC	Min.*	Max.**
075-085	6.6	26.2
095	6.7	27.0
105	9.1	36.2
115-125	9.3	37.0
135-145	11.2	44.7
160-170	14.1	56.3
185	16.4	65.5
215	17.0	67.9
250-280	21.0	84.0
300	22.2	88.7
315-370	26.8	107.2

30GX	Min.*	Max.**
080-090	5.8	21.0
105-115	6.3	26.5
125-135	7.4	31.8
150	9.1	36.0
160-175	10.8	41.9
205	12.4	46.0
225	14.5	54.0
250-265	16.5	60.0
280-300	18.0	66.0
325-350	21.0	72.0

\* Based on a water velocity of 0.9 m/s.  
 \*\* Based on a water velocity of 3.6 m/s.

## Condenser flow rate (l/s)

30HXC	Min.*		Max.**
	Closed loop	Open loop	
075-095	2.5	7.5	29.9
105	2.9	8.8	35.0
115	3.1	9.3	37.2
125	3.2	9.7	38.8
135-145	3.8	11.4	45.6
160	4.6	13.8	55.3
170	4.9	14.9	59.8
185	5.3	16.0	64.0
215-280	7.2	21.5	86.2
300-370	7.9	23.6	94.5

\* Based on a water velocity of 0.3 m/s in a closed loop and 0.9 m/s in an open loop.  
 \*\* Based on a water velocity of 3.6 m/s.

## Variable flow evaporator

Variable evaporator flow can be used in standard 30HXC and 30GX chillers. The chillers maintain a constant leaving water temperature under all flow conditions. For this to happen, the minimum flow rate must be higher than the minimum flow given in the table of permissible flow rates and must not vary by more than 10% per minute.

If the flow rate changes more rapidly, the system should contain a minimum of 6.5 liters of water per kW instead of 3.25 l/kW.

## System minimum water volume

Whichever the system, the water loop minimum capacity is given by the formula :

$$\text{Capacity} = \text{Cap (kW)} \times \text{N Liters}$$

Application	N
Normal air conditioning	3.25
Process type cooling	6.5

Where Cap is the nominal system cooling capacity (kW) at the nominal operating conditions of the installation.

This volume is necessary for stable operation and accurate temperature control.

It is often necessary to add a buffer water tank to the circuit in order to achieve the required volume. The tank must itself be internally baffled in order to ensure proper mixing of the liquid (water or brine). Refer to the examples below.

### NOTE

*The compressor must not restart more than 6 times in an hour.*

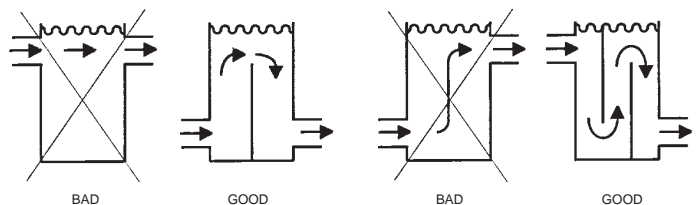

## Flow controllers

### Cooler flow switch and chilled water pump interlock

#### **IMPORTANT**

*It is mandatory to install cooler flow switch and also to connect chilled water pump interlock on 30HXC and 30GX units using flooded cooler. Failure to this instruction will void Carrier guarantee.*

The cooler flow switch controller is factory supplied and wired on 30HXC and 30GX units.

Follow the manufacturer instruction for installation.

The flow switch may be mounted in a horizontal pipe or a vertical pipe with upward liquid flow. It should not be used when liquid flow is downwards.

Mount in a section of pipe where there is a straight run of at least five pipe diameters on each side of the flow switch. Do not locate adjacent to valves, elbows or orifices. The paddle must never touch the pipe or any restriction in the pipe. Screw the flow switch in position so the flat part of the paddle is at right angles to the flow. The arrows on the cover and in the bottom, inside the case, must point in the direction of the flow. The switch should be mounted so that the terminals are accessible for easy wiring.

Terminals 34 and 35 are provided for field installation of a chilled water pump interlock (auxiliary contact of chilled water pump contactor).

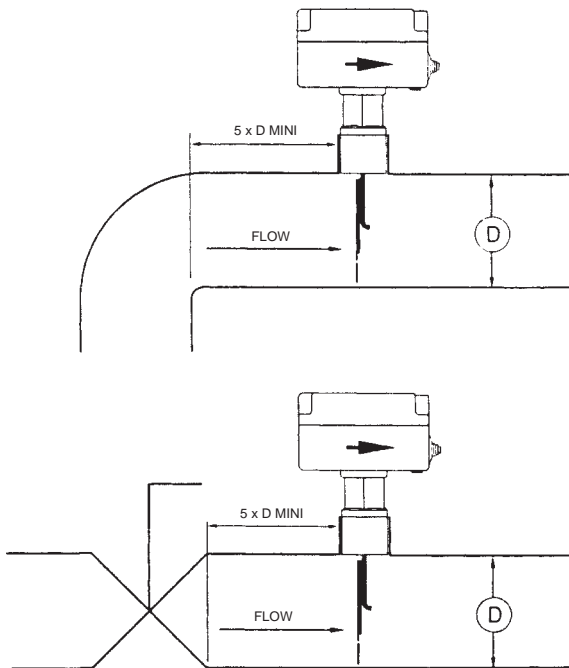

### Condenser flow switch (30HXC)

The condenser flow switch controller is a field installed device. It is configurable from the HSIO II when <2> <SRVC> is entered.

## INSTALLATION

### Check equipment received

- Inspect the unit for damage or missing parts. If damage is detected, or if shipment is incomplete, immediately file a claim with the shipping company.
- Confirm that the unit received is the one ordered. Compare the nameplate data with the order.
- Confirm that all accessories ordered for on-site installation have been delivered, and are complete and undamaged.
- Do not store units in an area exposed to weather because of sensitive control mechanism and electronic devices.

### Moving and siting the unit

#### Moving

Do not remove skids, pallets or protective packaging until the unit is in its final position. Move the chiller using tubes or rollers, or lift it, using slings of the correct capacity.

#### **CAUTION (30HXC)**

*Only use slings at the designated lifting points which are marked on the unit, on the top of the cooler heat exchanger. Rigging from the bottom of the heat exchanger will cause the unit to be lifted unsafely. Personal injury or damage to the unit may occur. Follow the rigging instruction given on the certified dimensional drawing supplied with the unit.*

#### Siting

Always refer to the chapter "Dimensions and clearances" to confirm that there is adequate space for all connections and service operation. For the center of gravity coordinates, the position of the unit mounting holes, and the weight distribution points, refer to the certified dimensional drawing supplied with the unit.

We recommend that these chillers be installed either in a basement or at ground level. If one is to be installed above ground level, first check that the permissible floor loading is adequate and that the floor is strong enough and level. If necessary, strengthen and level the floor.

With the chiller in its final location remove the skids, and other devices used to aid in moving it. Level the unit using a spirit level, and bolt the unit to the floor or plinth. Operation of these units may be impaired if they are not level and not securely fixed to their mountings. If required use isolation pads under the unit to aid in vibration isolation.

# LIFTING INSTRUCTIONS

## 30HXC 075-185

This diagram is shown for information only. Refer to “certified drawings” delivered with the unit.

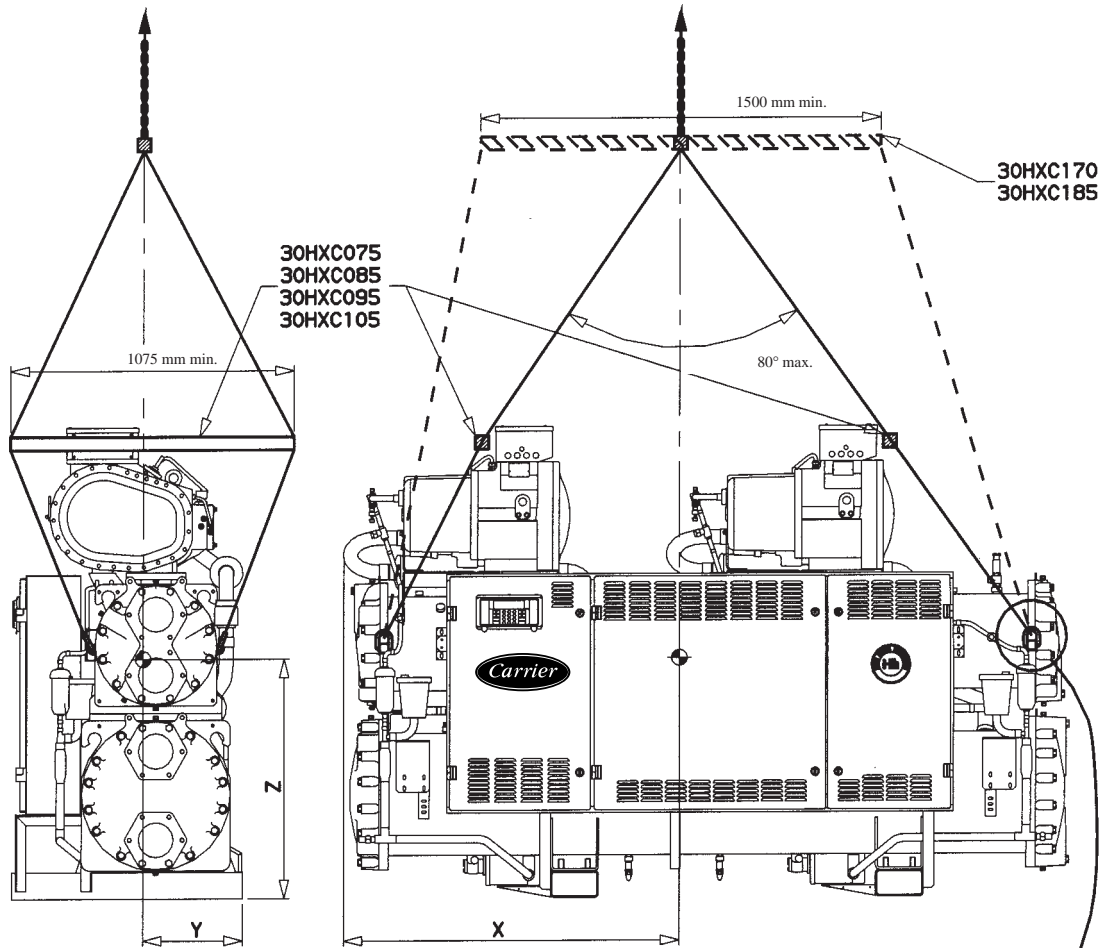

⊙ CENTER OF GRAVITY

30HXC	X (mm)	Y (mm)	Z (mm)
075-095	1265	376.5	900
105	1265	376.5	950
115-145	1665	376.5	900
160	1855	371.5	950
170-185	1855	380.5	950

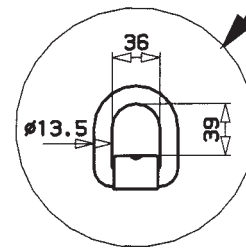

4 LIFTING LUGS (SEE NOTE)

### NOTE

When all lifting and positioning operations are finished, it is recommended to touch up all surfaces where paint has been removed on lifting lugs.

## LIFTING INSTRUCTIONS (CONT.)

### 30HXC 215-280

This diagram is shown for information only. Refer to “certified drawings” delivered with the unit.

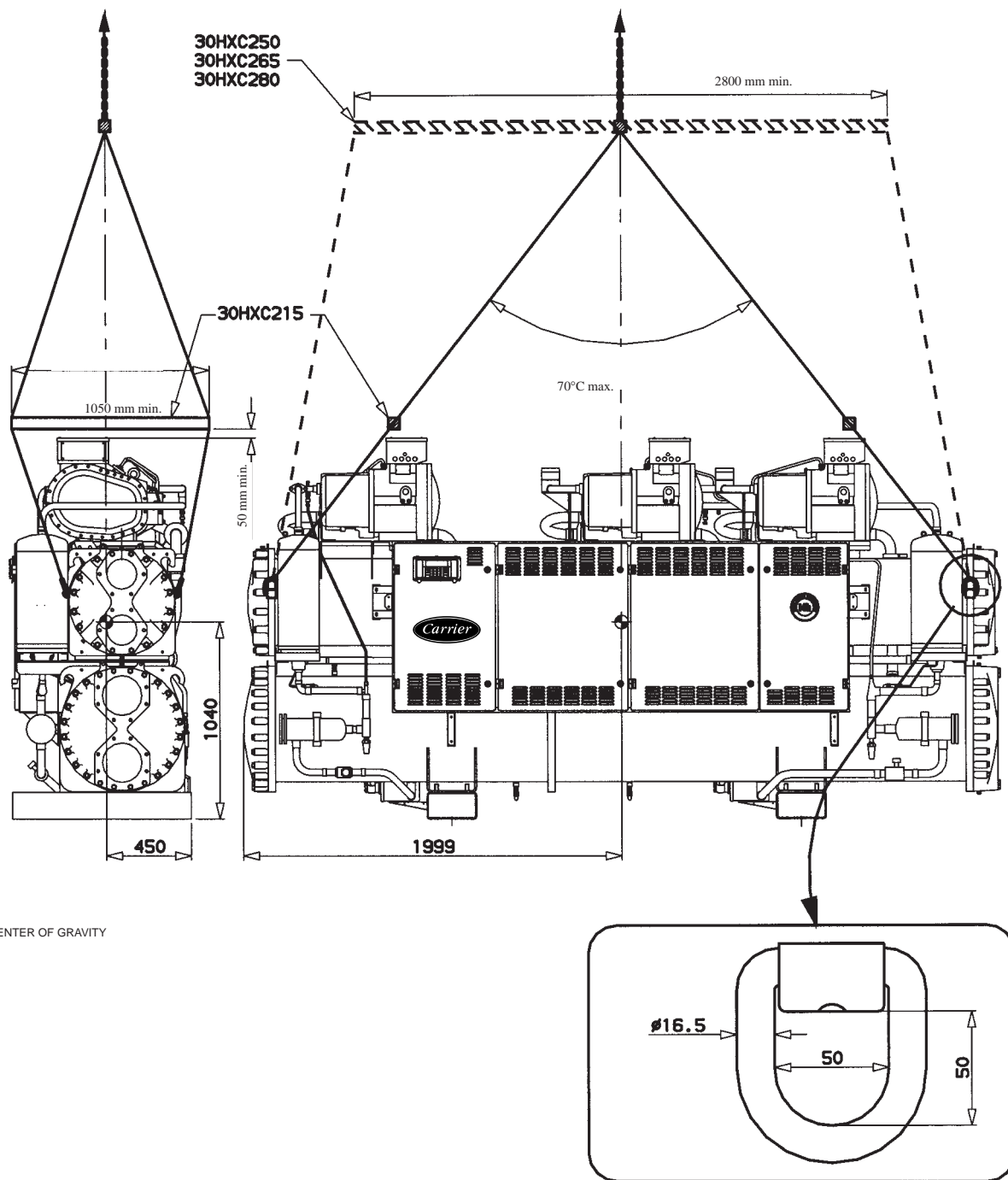

#### NOTE

When all lifting and positioning operations are finished, it is recommended to touch up all surfaces where paint has been removed on lifting lugs.

## LIFTING INSTRUCTIONS (CONT.)

### 30HXC 300-370

This diagram is shown for information only. Refer to “certified drawings” delivered with the unit.

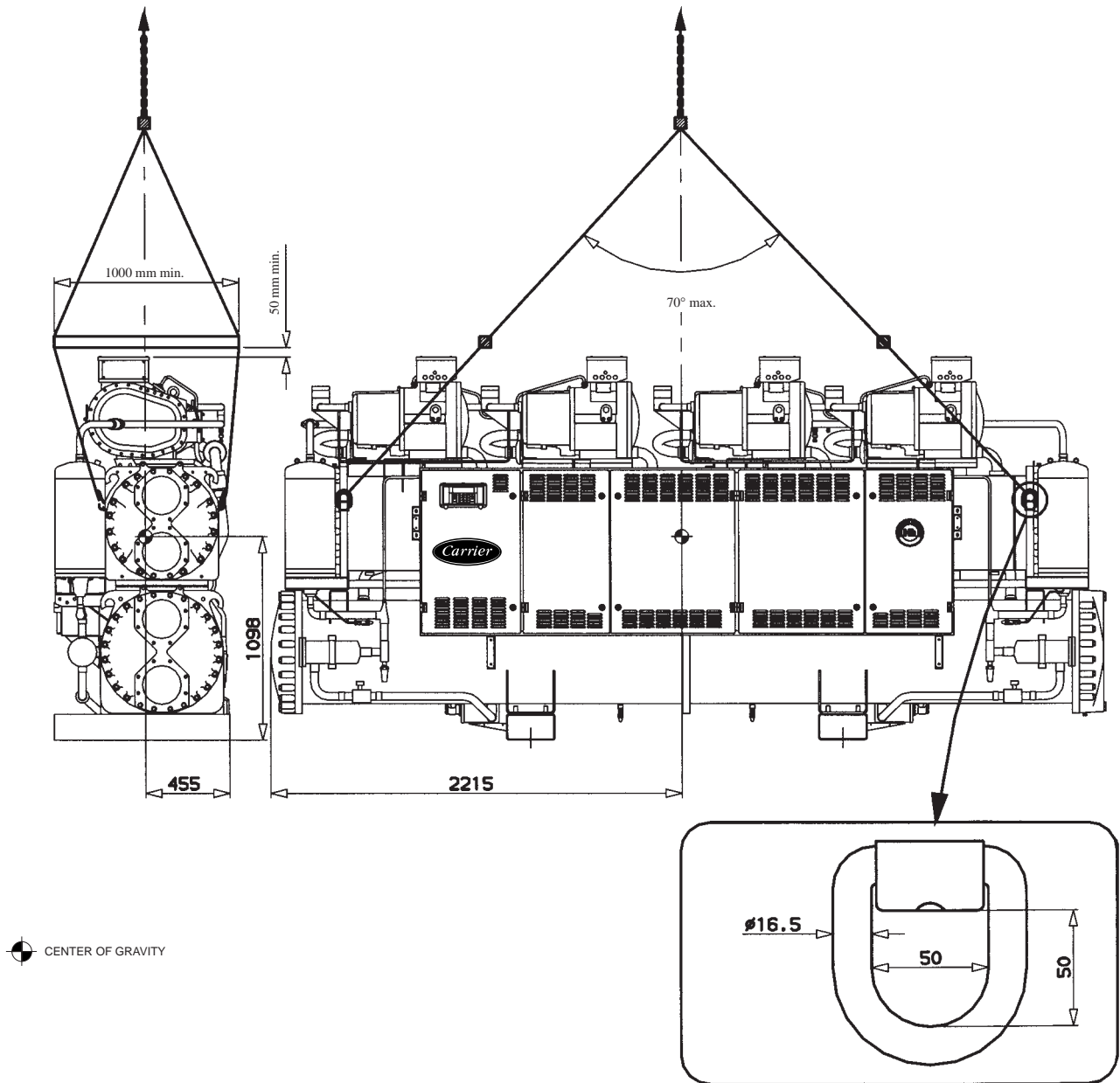

#### NOTE

When all lifting and positioning operations are finished, it is recommended to touch up all surfaces where paint has been removed on lifting lugs.

## LIFTING INSTRUCTIONS (CONT.)

### 30GX 080-160

This diagram is shown for information only. Refer to “certified drawings” delivered with the unit.

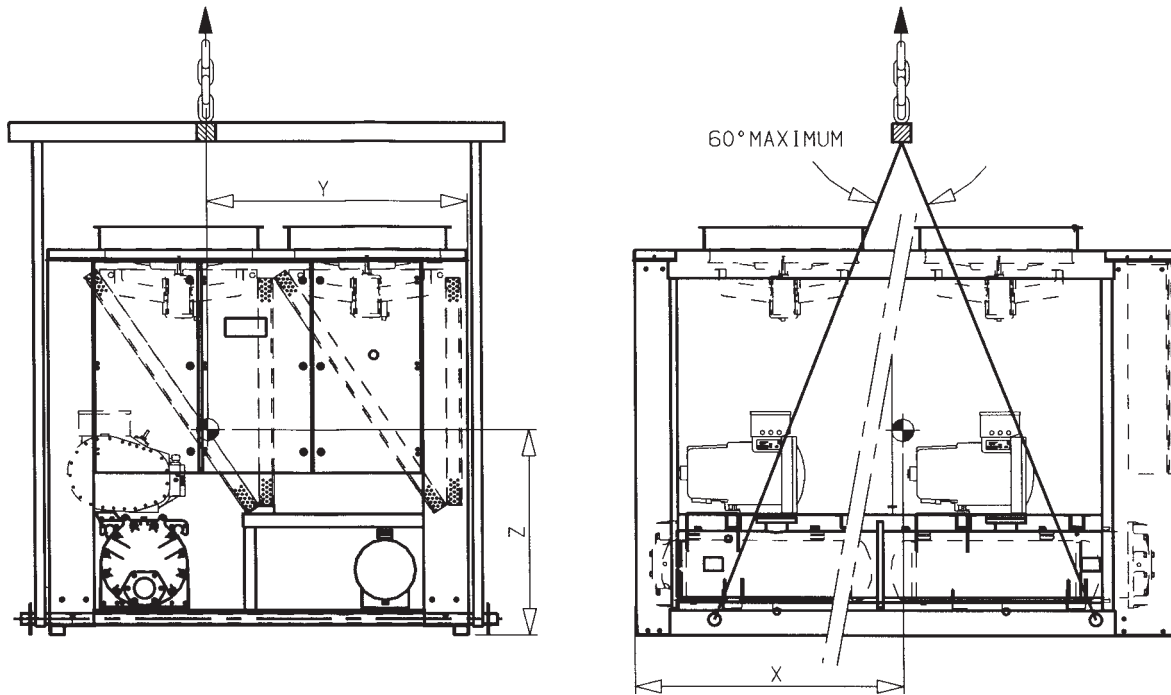

30GX	X (mm)	Y (mm)	Z (mm)
080	1550	1391	932
090-105	1550	1391	982
115-135	1800	1391	982
150-160	2186	1391	932

### 30GX 175

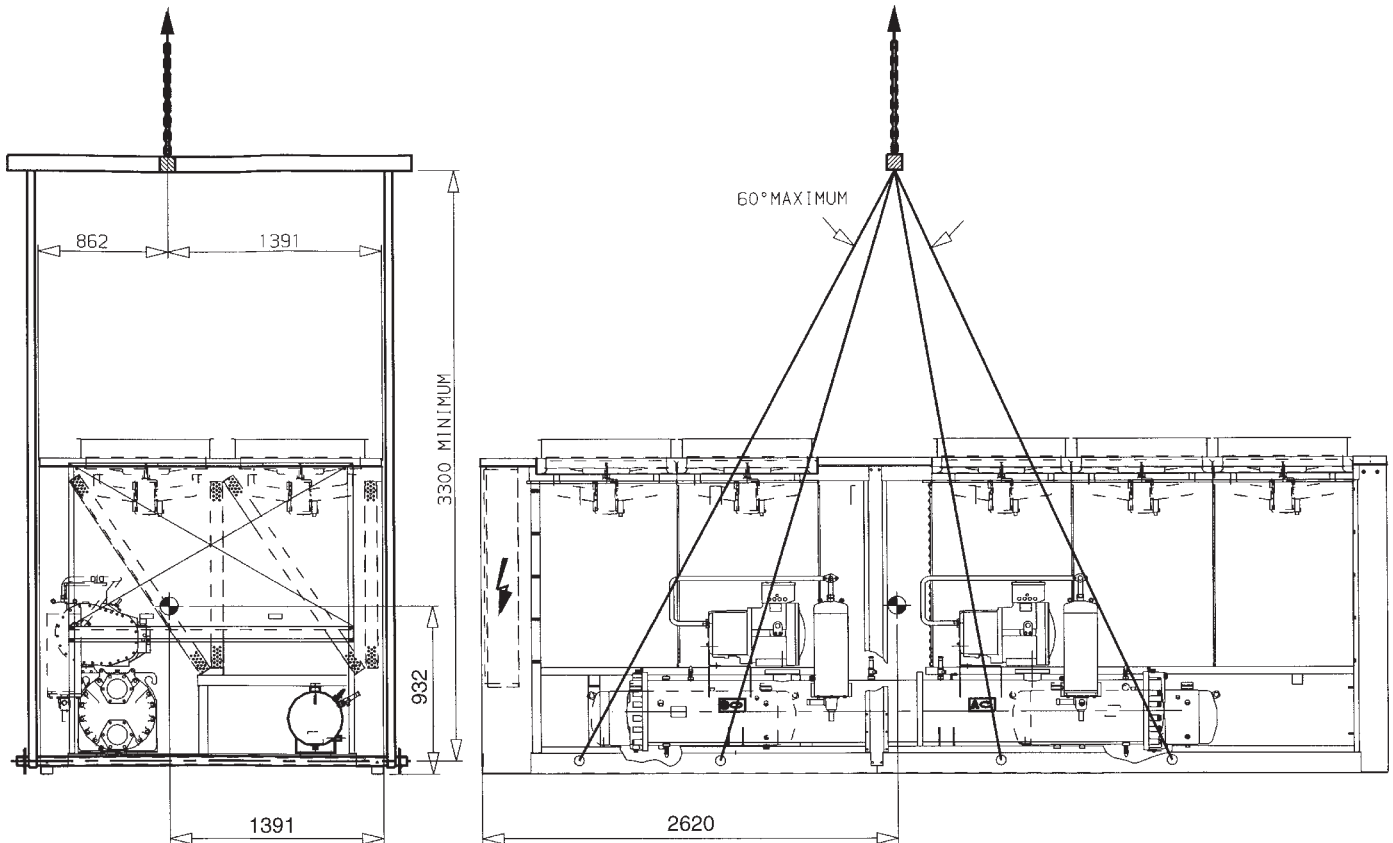



## LIFTING INSTRUCTIONS (CONT.)

### 30GX 205-265

This diagram is shown for information only. Refer to “certified drawings” delivered with the unit.

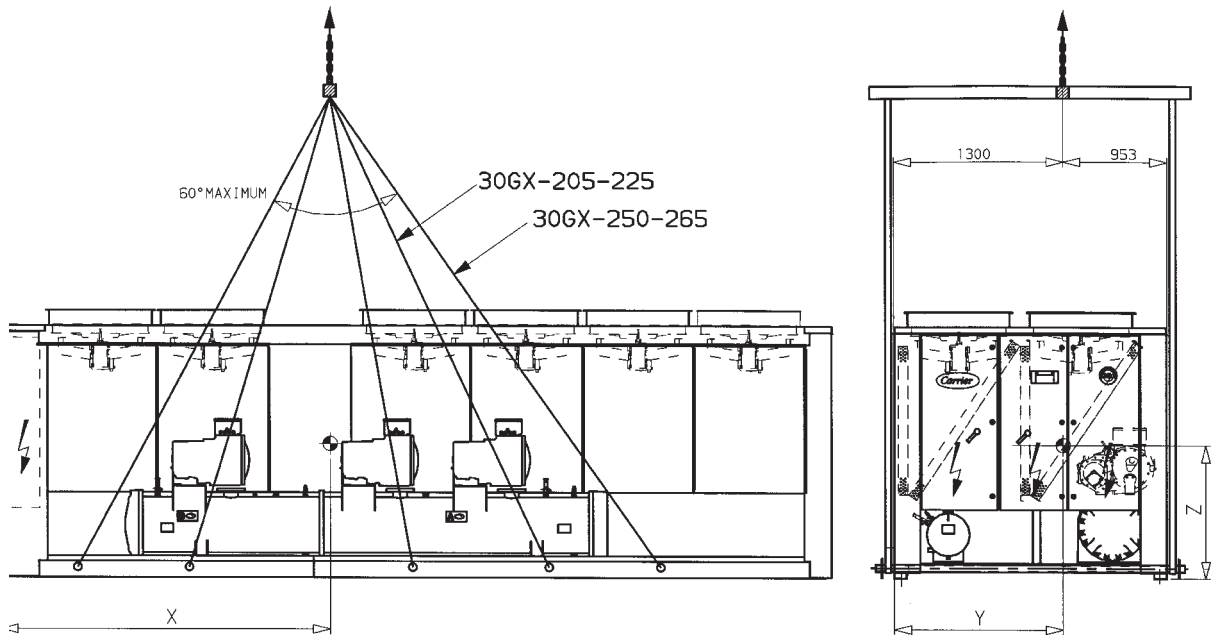

30GX	X (mm)	Y (mm)	Z (mm)
205-225	2878	1300	900
250-265	3044	1300	900

### 30GX 280-350

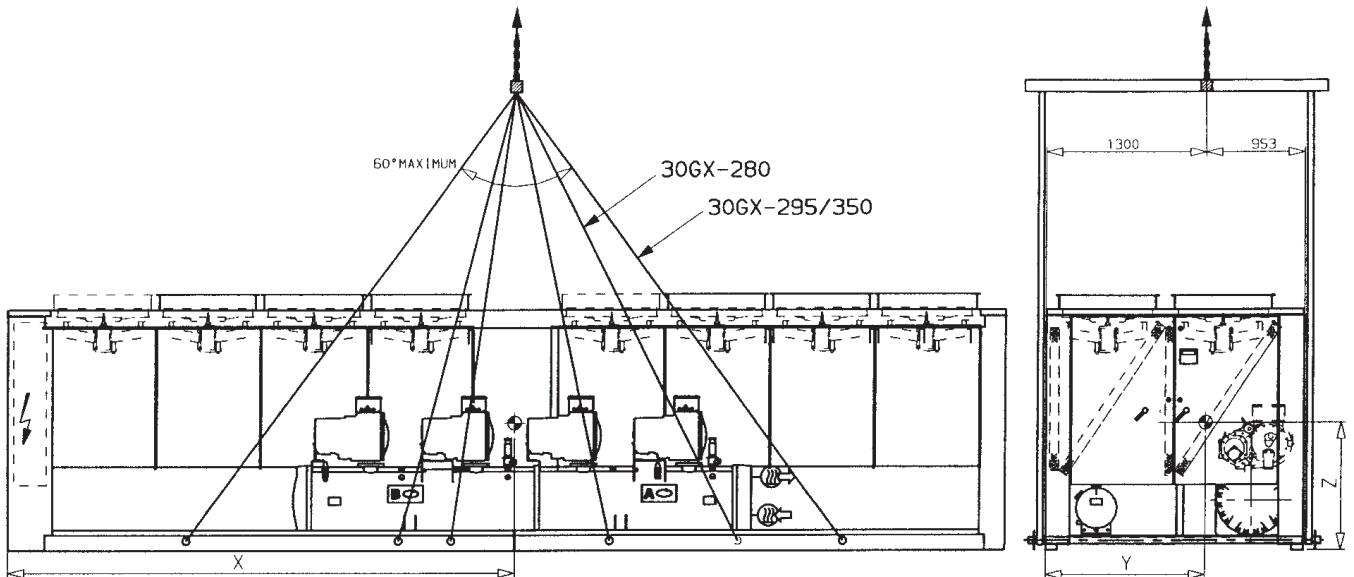

 CENTER OF GRAVITY

30GX	X (mm)	Y (mm)	Z (mm)
280	3412	1300	900
295	3500	1300	900
325-350	4325	1300	900

## PIPING CONNECTIONS

Refer to the certified dimensional drawings for the sizes and positions of all water inlet and outlet connections. The water pipes must not transmit any radial or axial force to the heat exchangers or any vibration to the pipework or building.

The water supply must be analysed and appropriate filtering, treatment, control devices, isolation and bleed valves and circuits built in, as necessary. Consult either a water treatment specialist or appropriate literature on the subject.

### Operating precautions

The water circuit should be designed to have the least number of elbows and horizontal pipe runs at different levels. The following basic checks should be done (see also the illustration of a typical hydraulic circuit below).

- Note the water inlets and outlets of the heat exchangers.
- Install manual or automatic air purge valves at all high points in the water circuit.
- Use an expansion chamber or an expansion/relief valve to maintain pressure in the system.
- Install water thermometers in both the entering and leaving water connections close to the evaporator.
- Install drain valves at all low points to allow the whole circuit to be drained. Connect a stop valve in the drain line before operating the chiller.
- Install stop valves, close to the evaporator, in the entering and leaving water lines.
- Install cooler flow switch.
- Use flexible connections to reduce the transmission of vibration to the pipework.
- Insulate all pipework, after testing for leaks, both to reduce thermal leaks and to prevent condensation.
- Cover the insulation with a vapour barrier.

### Cooler and condenser connections

The cooler and condenser are of the multi-tube shell and tube type with removable water boxes to facilitate cleaning of the tubes.

Before making water connections tighten the bolts in both heads to the lower torque shown, following the method described. Tighten in the pairs and sequence indicated according to the size of bolt (see table) using a torque value at the low end of the range given.

#### CAUTION

*Remove the factory supplied flat flange from the water box before welding piping to the flange. Failure to remove the flange may damage the sensors and insulation.*

### Pipe connections

After welding the pipes to the flanges previously removed from the water boxes :

- Reinstall the pipes and tighten lightly to a torque at the low end of the range.
- Fill the system with water.
- Wait for 10 minutes and check for minor leaks
  - at the water box joints
  - at the flange joints
- Drain the system.

- Disconnect the pipework.
- Tighten the head bolts to their final torque (middle of the range) in the sequence illustrated.
- Reconnect the pipes, tightening the flange bolts to the mid-range torque value.
- Refill the system with water.
- Pressurize the system.

#### NOTE

*We recommend draining the system and disconnecting the pipework to ensure that the bolts of the heads to which the pipework is connected are correctly and uniformly tightened.*

If there is a leak outside the water head :

- Drain the system.
- Disconnect the water pipes.
- In the correct sequence, retighten the head bolts to the maximum torque given for the bolt size.
- Reconnect the pipework, tightening the bolts to their final torque value, i.e. the middle value in the range given for the bolt size.
- Refill the system with water.
- Pressurize the system.

#### IMPORTANT

*Before starting the unit, be sure all of the air has been purged from the system.*

### Freeze protection

Cooler and water-cooled condenser protection

If the chiller or the water piping is in an area where the ambient temperature can fall below 0°C it is recommended to add an antifreeze solution to protect the unit and the water piping to a temperature of 8 K below the lowest anticipated temperature.

Use only antifreeze solutions, approved for heat exchanger duty. If the system is not protected by an antifreeze solution and will not be used during the freezing weather conditions, draining of the cooler and outdoor piping is mandatory.

### Water box tightening sequence

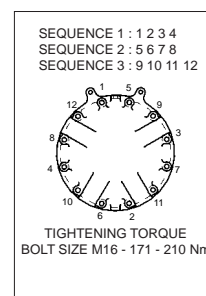

### Typical hydraulic circuit diagram

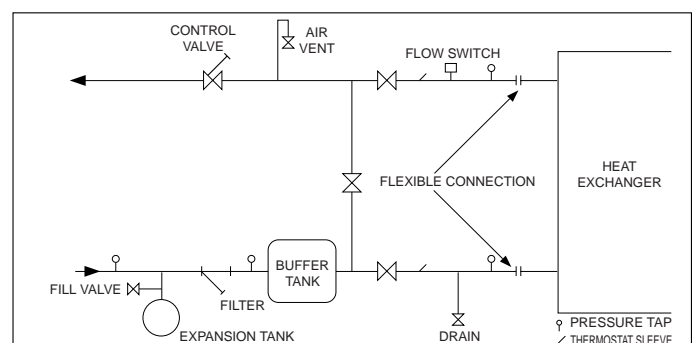

## ELECTRICAL CHARACTERISTICS

- The 30HXC 075-185 and 30GX 080-175 have only one power terminal block.
- The 30HXC 215-370 and 30GX 205-350 have two power terminal blocks.
- The control box incorporates the following as standard :
  - Starters and motor protection devices for each compressor and the fans
  - Control components
- Connections on site :  
All mains connections and electrical installation must be carried out in accordance with the European directives applicable to the site.
- The 30HXC and 30GX are designed to facilitate compliance with these directives. The engineering of the electrical equipment for the 30HXC and 30GX takes account of European standard EN 60204-1 (safety of machinery - electrical equipment of machines - Part 1 : general rules).

### IMPORTANT

- Standard EN 60204-1 is a good means of responding to the requirements of the Machinery Directive § 1.5.1. The normative recommendation IEC 364, is generally recognized as meeting the requirements of the installation regulation.
- Annex B of standard EN 60204-1 may be used to describe the electrical characteristics under which the machines operate.

### 30HXC

- The operating conditions for a standard 30HXC are described below:
  - Environmental conditions<sup>(1)</sup>. The environmental classification is described in standard IEC 364 § 3 :
    - Ambient temperature range: + 6°C to + 40°C, classification AA4
    - Humidity range (non condensing)
      - 50 % rh at 40°C
      - 90 % rh at 20°C
    - Altitude ≤ 2000 m<sup>(1)</sup>
    - For indoor installation
    - Presence of water : classification AD2<sup>(1)</sup> (possibility of water droplets)
    - Presence of solids: classification AE2<sup>(1)</sup> (presence of insignificant particulates)
    - Presence of corrosives and contaminants, classification AF1 (negligible)
    - Vibration, shock: classification AG2, AH2

Competence of personnel: classification BA4<sup>(1)</sup> (personnel qualified in accordance with IEC 364).

<sup>(1)</sup> The protection standard required in respect of this classification is IP21B (in accordance with the reference document IEC 529). All 30HXC have a protection standard of IP23C and therefore fulfil this protection requirement.

### 30GX

- The operating conditions for 30GX are described below :
  - Environmental conditions<sup>(2)</sup>. The environmental classification is described in standard EN 60721:
    - For outdoor installation<sup>(2)</sup>
    - Ambient temperature range: - 25°C to + 46°C, classification 4K3<sup>(2)</sup>
    - Altitude ≤ 2000 m<sup>(2)</sup>
    - Presence of solids: classification 422 (presence of

insignificant particulates)

- Presence of corrosives and contaminants, classification 4C2 (negligible)
- Vibration, shock : classification 4M2

Competence of personnel : classification BA4<sup>(2)</sup> (personnel qualified in accordance with IEC 364).

<sup>(2)</sup> The protection standard required in respect of this classification is IP43BW (in accordance with the reference document IEC 529). All 30GX have a protection standard of IP44CW and therefore fulfil this protection requirement.

### 30HXC/GX

- Fluctuation in power supply frequency : ± 2 Hz
- Overcurrent protection for the power supply conductors is not supplied with the device.
- The factory-fitted isolating switch (if ordered) is a type “a” isolator. (EN60204-1 § 5.3.2).

### NOTE

*If particular aspects of an installation require characteristics other than those listed above (or characteristics not referred to here) contact your Carrier representative.*

### Power supply

The power supply must conform to the specification on the chiller nameplate. The supply voltage must be within the range specified in the electrical data table.

For connections refer to the wiring diagrams.

### WARNING

*Operation of the chiller with an improper supply voltage or excessive phase imbalance constitutes abuse which will invalidate the Carrier warranty. If the phase imbalance exceeds 2% for voltage, or 10% for current, contact your local electricity supply at once and ensure that the chiller is not switched on until corrective measures have been taken.*

### Voltage phase imbalance (%) :

$$\frac{100 \times \text{max. deviation from average voltage}}{\text{Average voltage}}$$

### Example :

On a 400 V - 3 ph - 50 Hz supply, the individual phase voltages were measured to be :

$$\begin{aligned} AB &= 406 \text{ V} ; BC = 399 ; AC = 394 \text{ V} \\ \text{Average voltage} &= (406 + 399 + 394)/3 = 1199/3 \\ &= 399.7 \text{ say } 400 \text{ V} \end{aligned}$$

Calculate the maximum deviation from the 400 V average :

$$\begin{aligned} (AB) &= 406 - 400 = 6 \\ (BC) &= 400 - 399 = 1 \\ (CA) &= 400 - 394 = 6 \end{aligned}$$

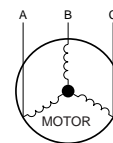

The maximum deviation from the average is 6 V. The greatest percentage deviation is :

$$100 \times 6/400 = 1.5 \%$$

This is less than the permissible 2 % and is therefore acceptable.

**FIELD POWER SUPPLY**

**30HXC 075-185**

**Electrical box**

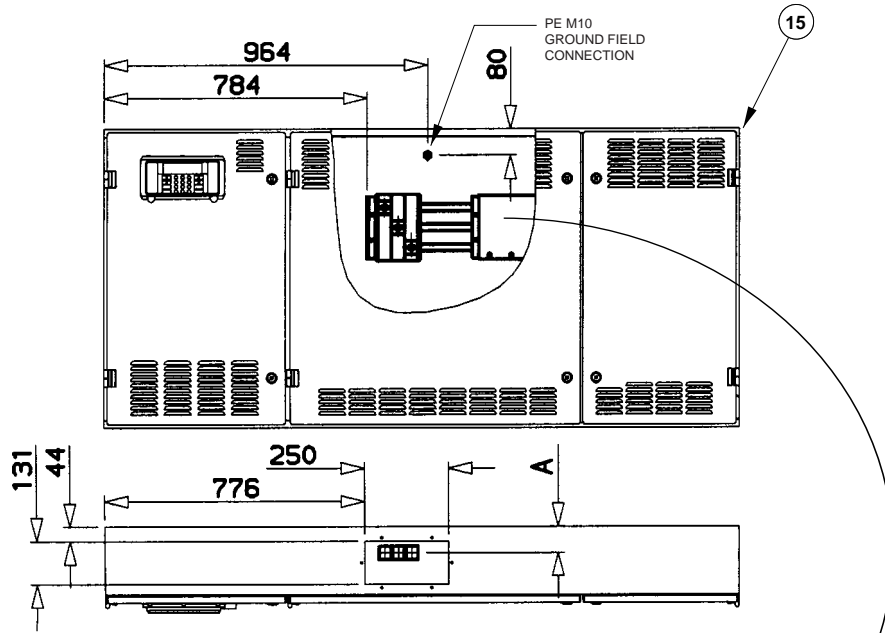

**Power terminal block**

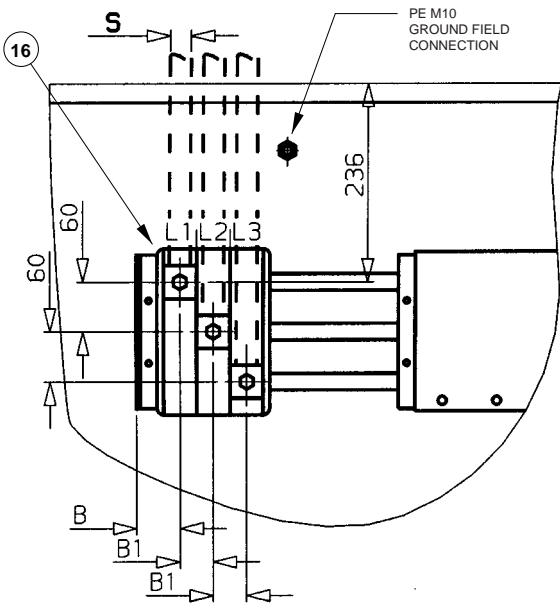

**Main disconnect switch**

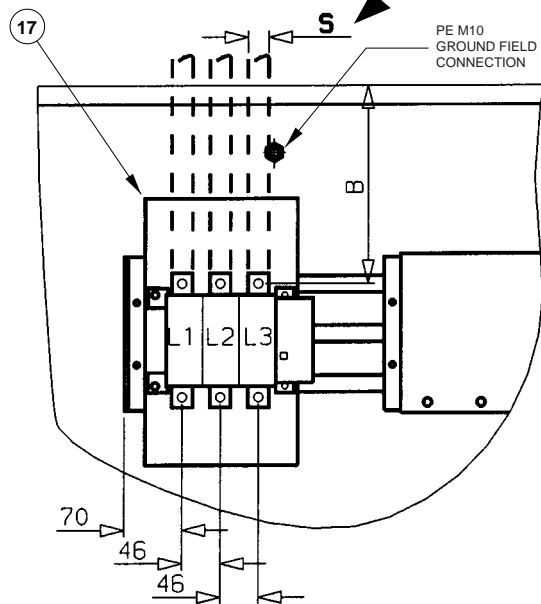

30HXC	A (mm)	B (mm)	B1 (mm)	S mm <sup>2</sup>	
				Min.	Max.
075-115	70	40	25	70	120
125	70	40	25	95	120
135-185	70	62.5	40	120	300

30HXC	A (mm)	B (mm)	S mm <sup>2</sup>	
			Min.	Max.
075-115	125	236	70	120
125	125	236	95	120
135-185	136	200	120	185

**IMPORTANT**

Before the connection of the main power cables (L1 - L2 - L3) on the power terminal block, it is imperative to check the right order of the 3 phases before proceeding to the connection on the terminal block or the main disconnect switch.

**FIELD CONTROL WIRING**

Refer to the Certified Electrical Wiring Diagram supplied with the unit for the field control wiring of the following features :

- Cooler pump interlock (mandatory)
- Remote on/off switch
- Condenser Flow Switch (Field supplied)
- Remote Heat / Cool switch

- Demand limit external switch 1
- Demand limit external switch 2
- Remote dual set point
- General alarm contact
- Cooler pump control (Option)
- Condenser pump control (Option)
- Outdoor air temperature (Option)
- Remote Reset 4-20 mA (Option)
- Demand limit 4-20 mA (Option)

## FIELD POWER SUPPLY (CONT.)

### 30HXC 215-280

#### Electrical box

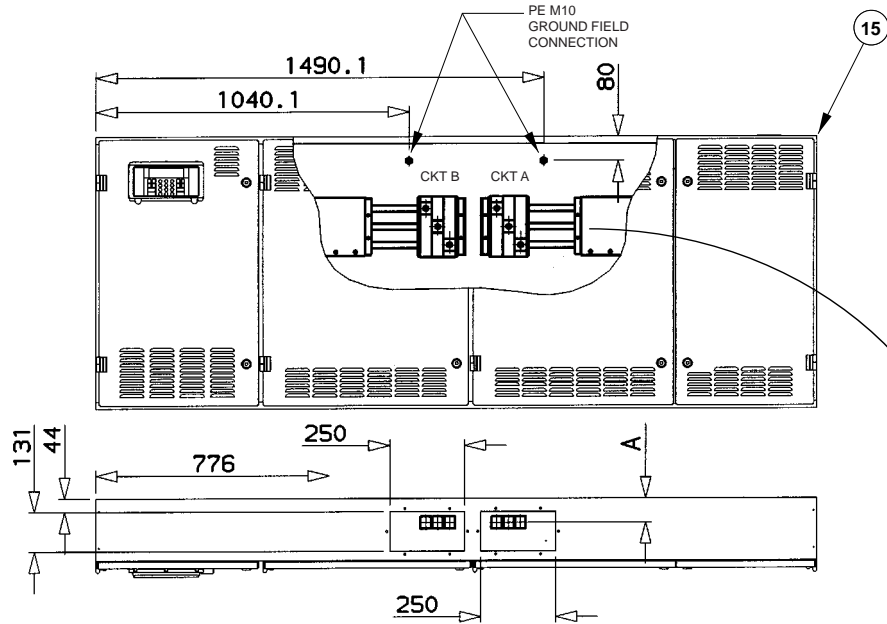

#### Power terminal block

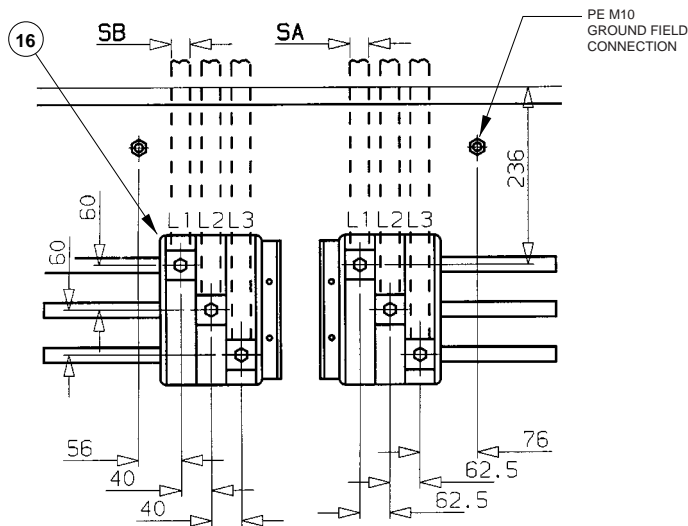

#### Main disconnect switch

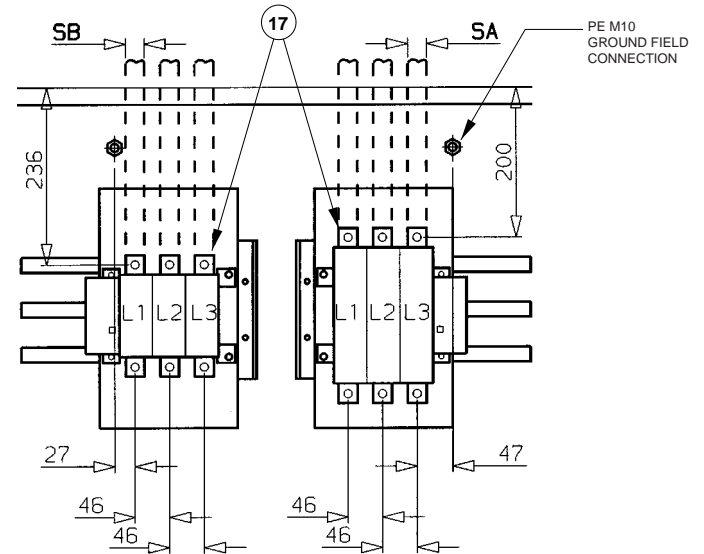

		SA mm <sup>2</sup>		SB mm <sup>2</sup>	
30HXC	A (mm)	Min.	Max.	Min.	Max.
215-280	70	120	300	70	120

		SA mm <sup>2</sup>		SB mm <sup>2</sup>	
30HXC	A (mm)	Min.	Max.	Min.	Max.
215-280	125	120	185	70	120

#### IMPORTANT

Before the connection of the main power cables (L1 - L2 - L3) on the power terminal block, it is imperative to check the right order of the 3 phases before proceeding to the connection on the terminal block or the main disconnect switch.

#### FIELD CONTROL WIRING

Refer to the Certified Electrical Wiring Diagram supplied with the unit for the field control wiring of the following features :

- Cooler pump interlock (mandatory)
- Remote on/off switch
- Condenser Flow Switch (Field supplied)
- Remote Heat / Cool switch

- Demand limit external switch 1
- Demand limit external switch 2
- Remote dual set point
- General alarm contact
- Cooler pump control (Option)
- Condenser pump control (Option)
- Outdoor air temperature (Option)
- Remote Reset 4-20 mA (Option)
- Demand limit 4-20 mA (Option)

**FIELD POWER SUPPLY (CONT.)**

**30HXC 300-370**

**Electrical box**

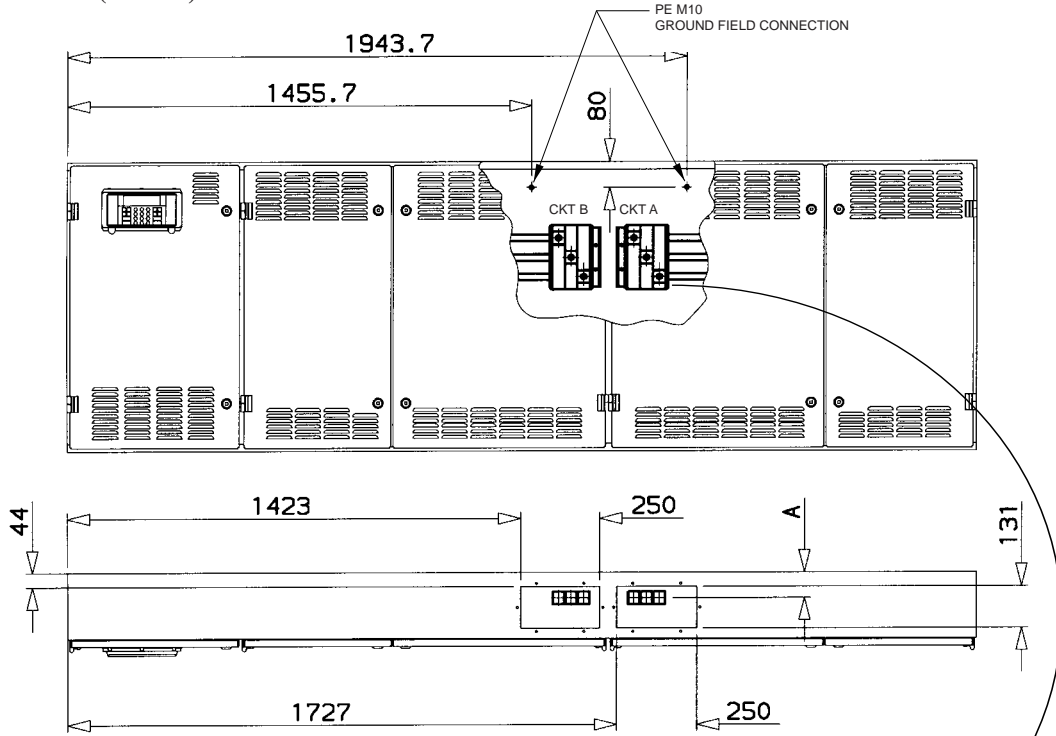

**Power terminal block**

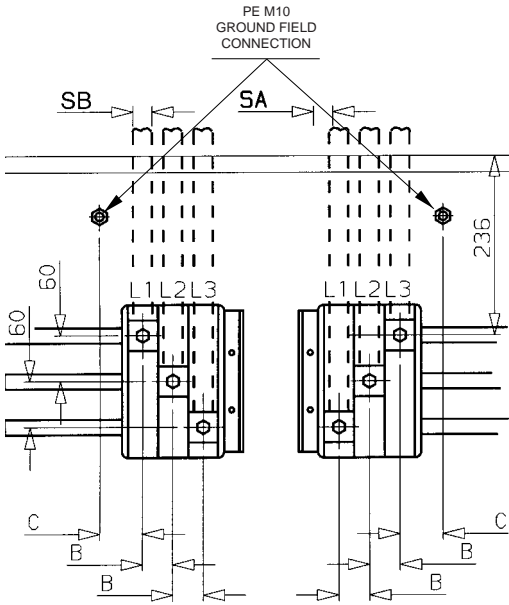

**Main disconnect switch**

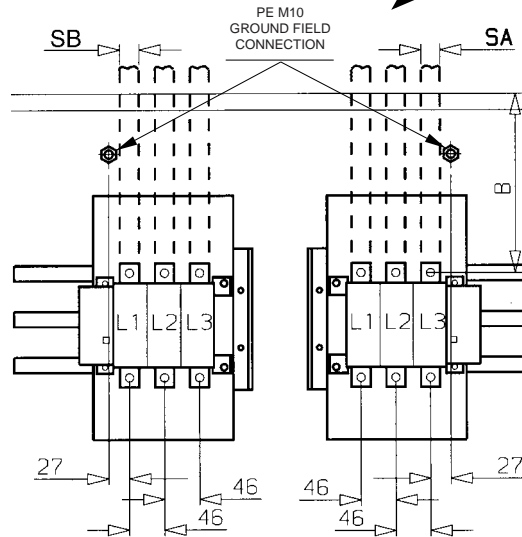

30HXC	A (mm)	B (mm)	C (mm)	SA mm <sup>2</sup>		SB mm <sup>2</sup>	
				Min.	Max.	Min.	Max.
300	70	40	85	95	120		
315-370	70	62.5	40	120	300		

30HXC	A (mm)	B (mm)	SA mm <sup>2</sup>		SB mm <sup>2</sup>	
			Min.	Max.	Min.	Max.
300	125	236	95	120		
315-370	125	200	120	185		

**IMPORTANT**

*Before the connection of the main power cables (L1 - L2 - L3) on the power terminal block, it is imperative to check the right order of the 3 phases before proceeding to the connection on the terminal block or the main disconnect switch.*

**FIELD CONTROL WIRING**

Refer to the Certified Electrical Wiring Diagram supplied with the unit for the field control wiring of the following features :

- Cooler pump interlock (mandatory)
- Remote on/off switch
- Condenser Flow Switch (field-supplied)
- Remote Heat / Cool switch

- Demand limit external switch 1
- Demand limit external switch 2
- Remote dual set point
- General alarm contact
- Cooler pump control (Option)
- Condenser pump control (Option)
- Outdoor air temperature (Option)
- Remote Reset 4-20 mA (Option)
- Demand limit 4-20 mA (Option)

**FIELD POWER SUPPLY (CONT.)**

**30GX 080-160**

**Electrical box**

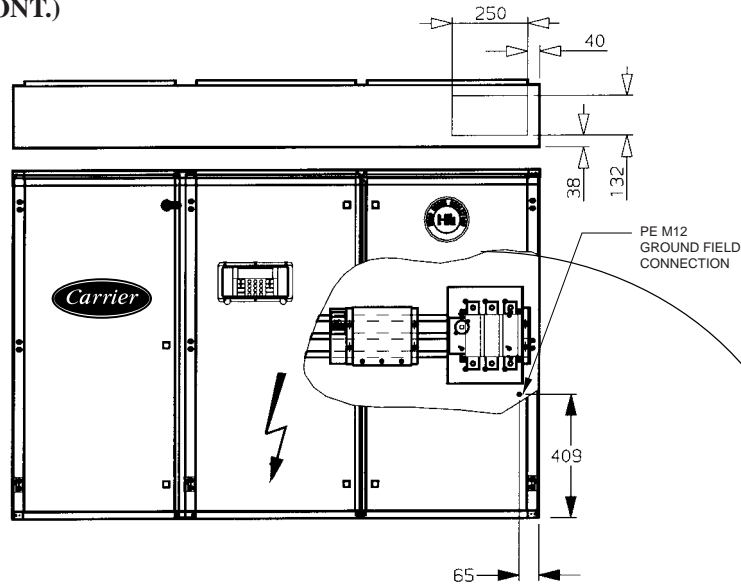

**Power terminal block**

**Main disconnect switch**

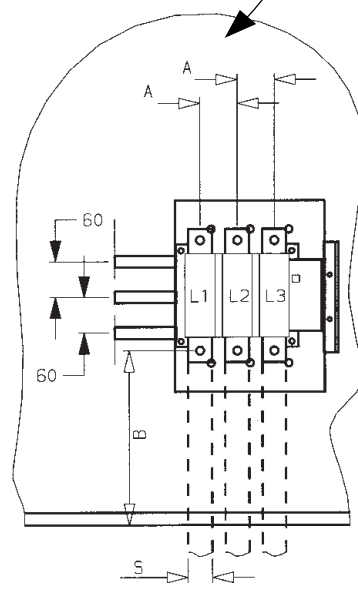
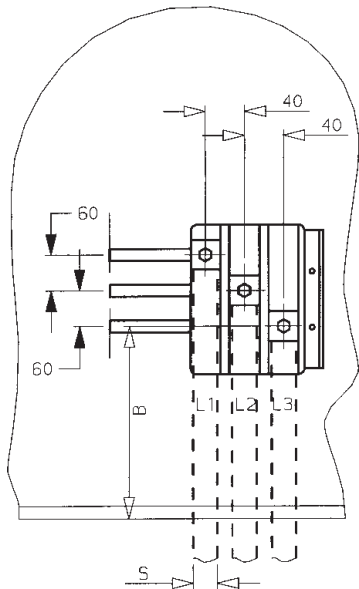

30GX	B (mm)	S mm <sup>2</sup>	
		Min.	Max.
080	540	120	300
090-105	540	150	300
115	540	185	300
125-135	540	240	300
150-160	540	2x95	2x120

30GX	A (mm)	B (mm)	S mm <sup>2</sup>	
			Min.	Max.
080	46	510	120	300
090-105	46	510	150	300
115	46	510	185	300
125-135	46	510	240	300
150	46	510	2x95	2x185
160	62	510	2x95	2x185

**IMPORTANT**

Before the connection of the main power cables (L1 - L2 - L3) on the power terminal block, it is imperative to check the right order of the 3 phases before proceeding to the connection on the terminal block or the main disconnect switch.

**FIELD CONTROL WIRING**

Refer to the Certified Electrical Wiring Diagram supplied with the unit for the field control wiring of the following features :

- Cooler pump interlock (mandatory)
- Remote on/off switch
- Remote Heat / Cool switch

- Demand limit external switch 1
- Demand limit external switch 2
- Remote dual set point
- General alarm contact
- Cooler pump control (Option)
- Outdoor air temperature (Option)
- Remote Reset 4-20 mA (Option)
- Demand limit 4-20 mA (Option)

## FIELD POWER SUPPLY (CONT.)

### 30GX 175

#### Electrical box

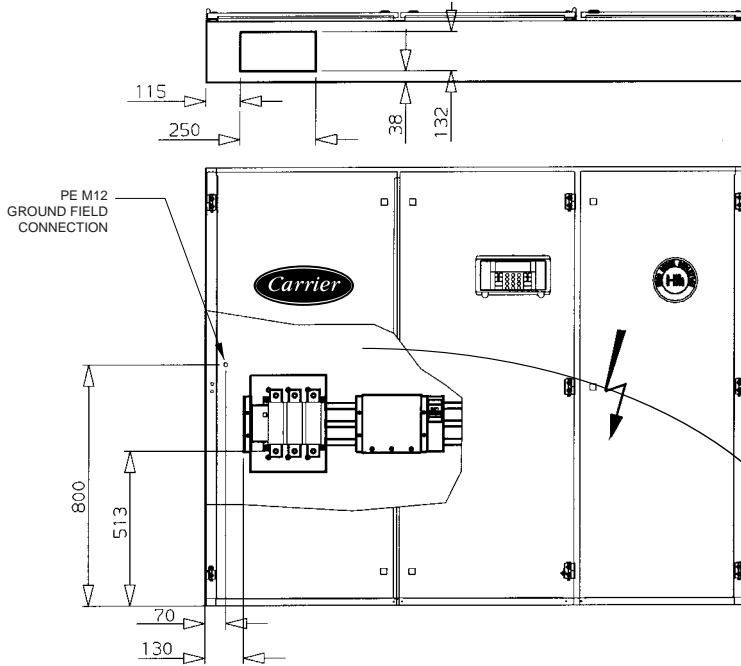

#### Power terminal block

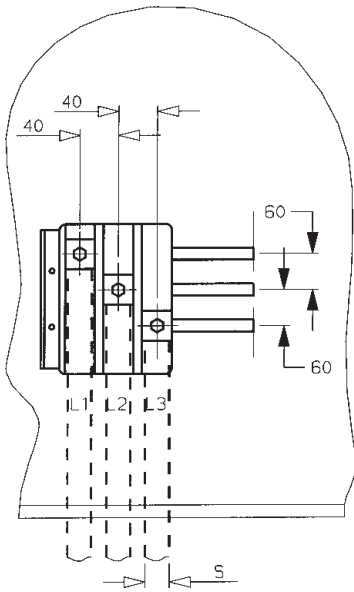

#### Main disconnect switch

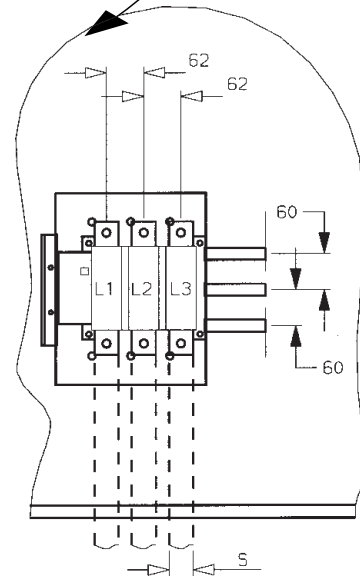

	S mm <sup>2</sup>	
	Min.	Max.
30GX		
175	2x120	2x300

	S mm <sup>2</sup>	
	Min.	Max.
30GX		
175	2x120	2x185

### **IMPORTANT**

*Before the connection of the main power cables (L1 - L2 - L3) on the power terminal block, it is imperative to check the right order of the 3 phases before proceeding to the connection on the terminal block or the main disconnect switch.*

### FIELD CONTROL WIRING

Refer to the Certified Electrical Wiring Diagram supplied with the unit for the field control wiring of the following features :

- Cooler pump interlock (mandatory)
- Remote on/off switch
- Remote Heat / Cool switch

- Demand limit external switch 1
- Demand limit external switch 2
- Remote dual set point
- General alarm contact
- Cooler pump control (Option)
- Outdoor air temperature (Option)
- Remote Reset 4-20 mA (Option)
- Demand limit 4-20 mA (Option)



**FIELD POWER SUPPLY (CONT.)**

**30GX 205-265**

**Electrical box**

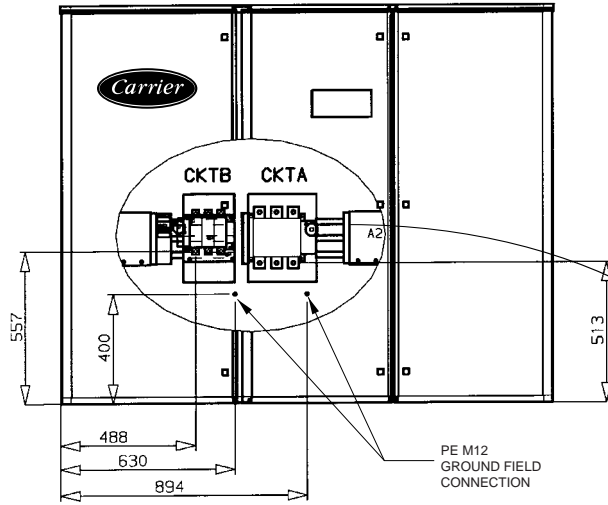
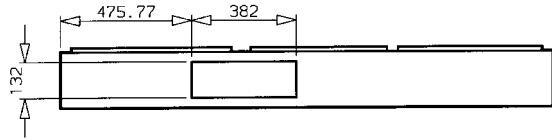

**Power terminal block**

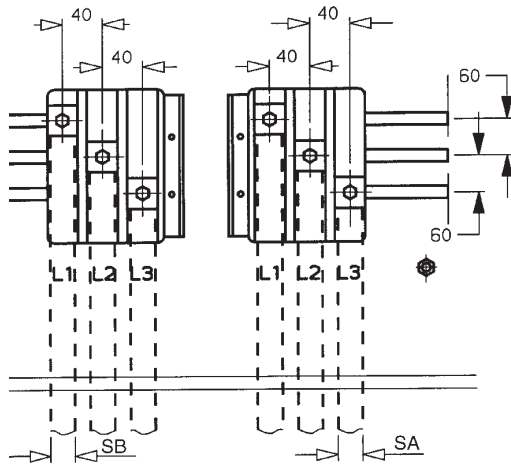

30GX	SA mm <sup>2</sup>		SB mm <sup>2</sup>	
	Min.	Max.	Min.	Max.
205	240	300	95	120
225	240	300	120	300
250	2x120	2x300	120	300
265	2x150	2x300	120	300

**Main disconnect switch**

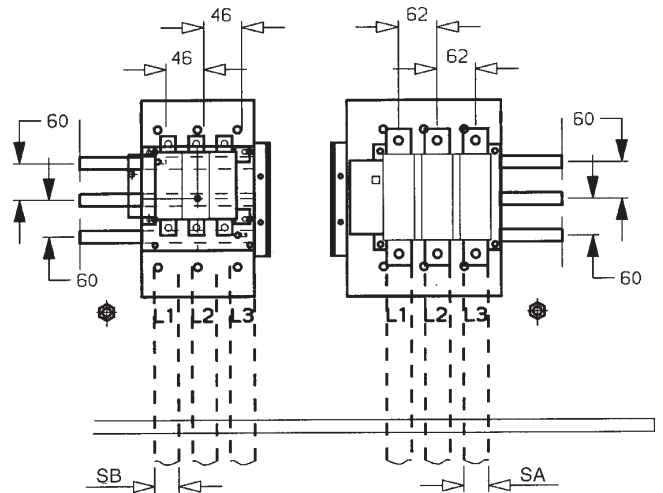

30GX	SA mm <sup>2</sup>		SB mm <sup>2</sup>	
	Min.	Max.	Min.	Max.
205	240	300	95	185
225	240	300	120	185
250	2x120	2x185	120	185
265	2x150	2x185	120	185

**IMPORTANT**

*Before the connection of the main power cables (L1 - L2 - L3) on the power terminal block, it is imperative to check the right order of the 3 phases before proceeding to the connection on the terminal block or the main disconnect switch.*

**FIELD CONTROL WIRING**

Refer to the Certified Electrical Wiring Diagram supplied with the unit for the field control wiring of the following features:

- Cooler pump interlock (mandatory)
- Remote on/off switch
- Remote Heat / Cool switch

- Demand limit external switch 1
- Demand limit external switch 2
- Remote dual set point
- General alarm contact
- Cooler pump control (Option)
- Outdoor air temperature (Option)
- Remote Reset 4-20 mA (Option)
- Demand limit 4-20 mA (Option)

**FIELD POWER SUPPLY (CONT.)**

**30GX 280-350**

**Electrical box**

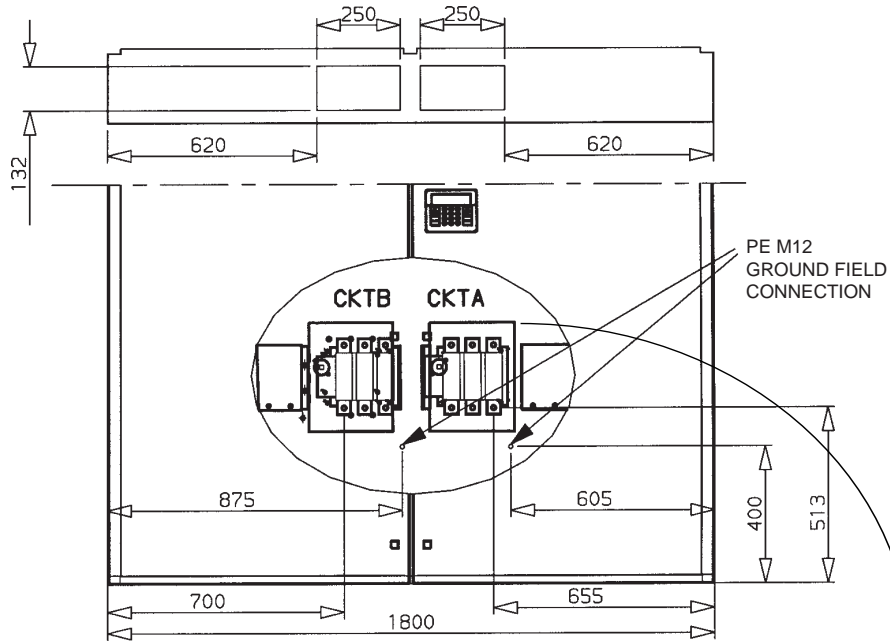

**Power terminal block**

**Main disconnect switch**

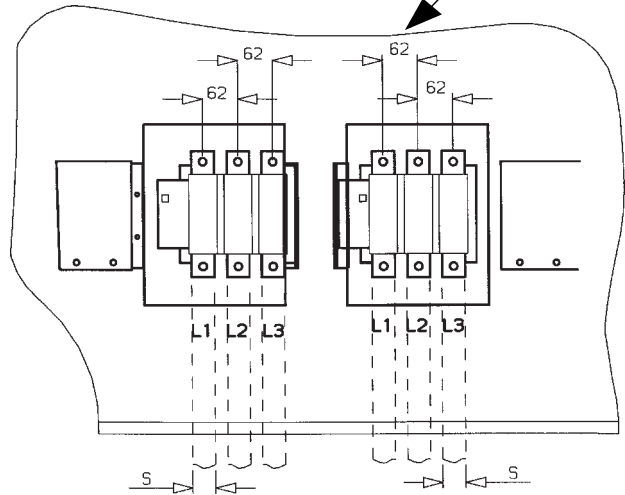
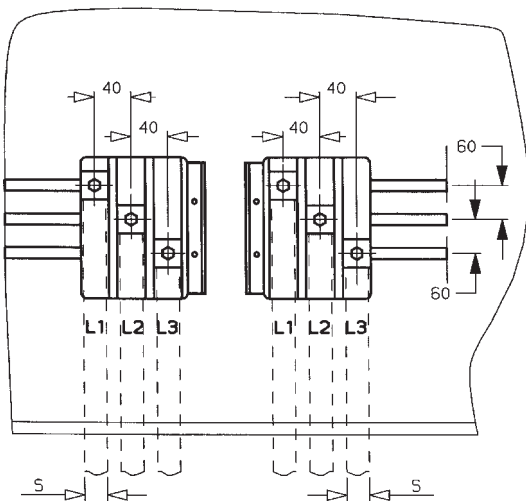

	SA mm <sup>2</sup>		SB mm <sup>2</sup>	
	Min.	Max.	Min.	Max.
30HXC			240	300
280-295	2x120	2x300	240	300
325	2x150	2x300	2x120	2x300
350	2x150	2x300	2x150	2x300

	SA mm <sup>2</sup>		SB mm <sup>2</sup>	
	Min.	Max.	Min.	Max.
30HXC			240	300
280-295	2x120	2x185	240	300
325	2x150	2x185	2x120	2x185
350	2x150	2x185	2x150	2x185

**IMPORTANT**

*Before the connection of the main power cables (L1 - L2 - L3) on the power terminal block, it is imperative to check the right order of the 3 phases before proceeding to the connection on the terminal block or the main disconnect switch.*

**FIELD CONTROL WIRING**

Refer to the Certified Electrical Wiring Diagram supplied with the unit for the field control wiring of the following features:

- Cooler pump interlock (mandatory)
- Remote on/off switch
- Remote Heat / Cool switch

- Demand limit external switch 1
- Demand limit external switch 2
- Remote dual set point
- General alarm contact
- Cooler pump control (Option)
- Outdoor air temperature (Option)
- Remote Reset 4-20 mA (Option)
- Demand limit 4-20 mA (Option)

## MAJOR SYSTEM COMPONENTS AND OPERATION DATA

### Geared twin screw compressor

- 30HXC and 30GX units use 06N geared twin screw compressors
- 06NA are used on 30GX (air-cooled condensing application)
- 06NW are used on 30HXC (water-cooled condensing application)
- Nominal capacities range from 39 to 80 tons. Economized or non economized models are used depending on the 30HXC and 30GX unit size.

### Oil Filter

The 06N screw compressor has an oil filter integral in the compressor housing. This filter is field replaceable.

### Refrigerant

The 06N screw compressor is specially designed to be used in R134a system only.

### Lubricant

The 06N screw compressor is approved for use with the following lubricant.

CARRIER MATERIAL SPEC PP 47-32

### Oil Supply Solenoid Valve

An oil supply solenoid valve is standard on the compressor to isolate the compressor from oil flow when the compressor is not operating. The oil solenoid is field replaceable.

### Suction & Economizer Screens

To increase the reliability of the compressor, a screen has been incorporated as a standard feature into suction and economizer inlets of the compressor.

### Unloading System

The 06N screw compressor has an unloading system that is standard on all compressors. This unloading system consists of two steps of unloading that decrease the compressor capacity by rerouting partially compressed gas back to suction.

### Cooler

30HXC and 30GX chillers use a flooded cooler. Flooded style coolers have refrigerant in the shell and water in the tubes. One vessel is used to serve both refrigerant circuits. There is a center tube sheet which separates the two refrigerant circuits. The tubes are 3/4" diameter copper with an enhanced surface inside and out. There is just one water circuit, and depending on the size of the chiller, there may be two or three water passes. A cooler liquid level sensor provides optimized flow control.

At the top of the cooler are the two suction pipes, one in each circuit. Each has a flange welded to it, and the compressor mounts on the flange.

### Condenser and oil separator (30HXC)

30HXC chiller use a vessel that is a combination condenser and oil separator. It is mounted below the cooler. Discharge gas leaves the compressor and flows through an external muffler to the oil separator, which is the upper portion of the vessel. It enters the top of the separator where oil is removed, and then flows to the bottom portion of the vessel, where gas is condensed and subcooled. One vessel is used to serve both refrigerant circuits. There is a center tube sheet

which separates the two refrigerant circuits. The tubes are 3/4" or 1" diameter copper with enhanced surface inside and out. There is just one water circuit with two water passes.

### Oil separator (30GX)

In the air-cooled units, the oil separator is a pressure vessel that is mounted under the outside vertical condenser coils. Discharge gas enters at the top of the separator where much of the oil separates and drains to the bottom. The gas then flows through a wire mesh screen where the remaining oil is separated and drains to the bottom.

### Electronic Expansion Device (EXD)

The microprocessor controls the EXD through the EXV control module. The EXD will either be an EXV or an Economizer. Inside both these devices is a linear actuator stepper motor.

High-pressure liquid refrigerant enters the valve through the bottom. A series of calibrated slots are located inside the orifice assembly. As refrigerant passes through the orifice, the pressure drops and the refrigerant changes to a 2-phase condition (liquid and vapor). To control refrigerant flow for different operating conditions, the sleeve moves up and down over the orifice, thereby changing orifice size. The sleeve is moved by a linear stepper motor. The stepper motor moves in increments and is controlled directly by the processor module. As the stepper motor rotates, motion is transferred into linear movement by the lead screw. Through the stepper motor and lead screws, 1500 discrete steps of motion are obtained. The large number of steps and long stroke result in very accurate control of refrigerant flow. Each circuit has a liquid level sensor mounted vertically into the top of the cooler shell. The level sensor consists of a small electric resistance heater and three thermistors wired in series positioned at different heights inside the body of the well. The heater is designed so that the thermistors will read approximately 93.3°C in dry air. As the refrigerant level rises in the cooler, the resistance of the closest thermistor(s) will greatly change. This large resistance difference allows the control to accurately maintain a specified level. The level sensor monitors the refrigerant liquid level in the cooler and sends this information to the PSIO-1. At initial start-up, the EXV position is at zero. After that, the microprocessor keeps accurate track of the valve position in order to use this information as input for the other control functions. It does this by initializing the EXV's at startup. The processor sends out enough closing pulses to the valve to move it from fully open to fully closed, then resets the position counter to zero. From this point on, until the initialization, the processor counts the total number of open and closed steps it has sent to each valve.

### Economizer

Economizers are installed on 30HXC 170 to 370 (except 30HXC 215) and 30GX 105 to 350.

The economizer improves both the chiller capacity and efficiency as well as providing compressor motor cooling. Inside the economizer are both a linear EXV stepper motor and a float valve. The EXV is controlled by the PIC to maintain the desired liquid level in the cooler (as is done for Non-Economized chillers). The float valve maintains a liquid level in the bottom of the economizer. Liquid refrigerant is supplied from the condenser to the bottom of the economizer. As the refrigerant passes through the EXV, its pressure is reduced to an intermediate level of about 500 kPa. This pressure is maintained inside the economizer shell. Next, the refrigerant flows through the float valve, its pressure is further reduced to slightly above the pressure in the cooler. The increase in performance is realized when some of the refrigerant passing through

the EXV flashes to vapor, further subcooling the liquid that is maintained at the bottom of the economizer. This increase in subcooling provides additional capacity. Since no additional power is required to accomplish this, the efficiency of the machine also improves. The vapor that flashes will rise to the economizer where it passes to the compressor and is used as needed to provide motor cooling. After passing over the motor windings, the refrigerant reenters the cycle at an intermediate port in the compression cycle.

## Oil pumps

The 30GX/HXC screw chillers use one externally mounted pre-lubricating oil pump per circuit. This pump is operated as part of the start-up sequence. On 30GX units, the pumps are mounted to the base rails on the oil separator side of the unit. The pumps are mounted to a bracket on the condensers of 30HXC units. When a circuit is required to start, the controls will energize the oil pump first and read the current oil pressure transducer reading. The pump will be operated for a period of 20 seconds, after which the oil solenoid will be energized to open the oil inlet valve at the compressor. The control will again read the pressure from the oil pressure transducer. If the pump has built up sufficient oil pressure, the compressor will be allowed to start. Once the compressor has started, the oil pump will be turned off within 10 seconds and will not be used again until the next start-up. If the pump was not able to build up enough oil pressure, the pump will be turned off. Within 3 seconds, the pump will be re-energized and will make one additional attempt to build oil pressure. The control will generate an alarm if the second attempt fails.

## Motor cooling valves

Compressor motor winding temperatures are controlled to a setpoint of 85°C. The control accomplishes this by cycling the motor cooling solenoid valve to allow liquid refrigerant to flow across the motor windings as needed. On units equipped with economizers, flash gas leaves the top of the economizer and continually flows to the motor windings. All refrigerant used for motor cooling re-enters the rotors through a port located midway along the compression cycle and is compressed to discharge pressure.

## Back pressure valve (GX only)

On GX units, this valve is located on the oil separator outlet. The valve's function is to ensure that there is sufficient system differential pressure to allow for oil to be driven back to the compressor. A small copper line (Economizer pressure) is connected to the top of the valve and an internal spring is connected to a valve which will close if the pressure in the oil separator is not at least 100 kPa greater than the economizer pressure.

## Sensors

The units use eight standard thermistors (including two motor temperature thermistors) and two level thermistors and eight standard pressure transducers to monitor and control system operation.

## Thermistors

### Cooler leaving fluid

This temperature is used to measure the leaving cooler fluid temperature (water or brine). The temperature is used for leaving fluid temperature control and to protect against cooler freeze-up. It is located in the cooler fluid nozzle.

### Cooler entering fluid

This sensor is used to measure the cooler entering fluid temperature. It is located in the entering cooler nozzle. It is used to provide automatic temperature compensation for the leaving fluid temperature control with entering fluid compensation.

### Discharge gas temperature (circuits A & B)

This sensor used to measure the discharge gas temperature and control the discharge temperature superheat. It is located on the discharge pipe of each circuit (30HXC) or on the top of the oil separator (30GX).

### Motor temperature

The Compressor Protection Module (CPM) monitors the motor temperature. Thermistor terminals are located in the compressor junction box.

### Cooler liquid level (circuits A & B)

Cooler liquid level thermistor is used to provide optimized flow control in the cooler. It is installed in the top of the cooler.

### Condenser entering fluid (optional on 30HXC)

This sensor is used to measure the temperature of the fluid entering the water cooled condensers. It is located in the common fluid line entering the condensers (field installed). On Heat Machines it is used by the capacity control routine. On water cooled condensers it is only used for monitoring of the condenser fluid temperature.

### Condenser leaving fluid (optional on 30HXC)

This sensor is used to measure the temperature of the fluid leaving the water cooled condensers. It is located in the common fluid line leaving the condensers (field installed). On Heat Machines it is used by the capacity control routine. On water cooled condensers it is only used for monitoring of the condenser fluid temperature.

### Space temperature, outdoor air temperature (optional)

These temperatures are used to measure the temperature of the space or the outside air temperature respectively for reset control based on Outside Air or Space Temperature reset options.

## Pressure transducers

### Discharge pressure (circuits A & B)

This input is used to measure the high side pressure of each circuit of the unit. It is located on the discharge pipe of each circuit (30HXC) or on the top of the oil separator (30GX). It is used to provide the pressure to replace the discharge pressure gauge and to control the head pressure.

### Suction pressure (circuits A & B)

This input is used to measure the pressure of the low side of the unit. It is located on the top of the cooler of each circuit.

### Oil pressure (each compressor)

This input is used to measure the oil pressure of each compressor of the unit. The economizer pressure is subtracted from this reading to determine the oil pressure differential. It is located on the oil pressure port of each compressor.

### Economizer pressure (circuits A & B)

This input is used to monitor the oil pressure differential supplied to the compressor. It is located on the economizer suction pipe of each circuit.

## Control components

### Processor module (PSIO)

It contains the operating software and controls the operation of the machine. It has 12 input channels and 6 output channels.

It continuously monitors input/output channel information received from all the modules and controls all output signals for all output channels. It also controls relays. The processor module also controls the EXV control module, commanding it to open or close each EXD in order to maintain the proper cooler level. Information is transmitted between the processor module, CPM modules, the EXV control module, the basic board and HSIO II display module through a 3-wire communications bus called COMM3.

### Basic board

It is used as input/output module as there is no unit software downloaded in this module. It contains 8 analogue inputs, 14 discrete inputs and 8 discrete outputs.

### Electronic expansion valve module

This module has four outputs. It receives signals from the PSIO module and operates the electronic expansion device.

### Optional control module

An optional control module with 4 analogue inputs and 2 discrete outputs is added for remote control. Demand limit control (4-20 mA) and chilled water temperature reset (4-20 mA).

### Control switch

Control of the chiller is defined by the position of the LOCAL/OFF/REMOTE (LOR) switch. This is a 3-position manual switch that allows the chiller to be put under the control of its own controls, manually stopped or controlled through a set of remote contacts. CCN control is done through the HSIO II. In the LOCAL position, the chiller is allowed to operate and respond to the scheduling configuration, CCN configuration and set point data. In the remote position the unit operates similar to the LOCAL position except the remote contact must be closed for the unit to be able to operate.

### Compressor Protection Module (CPM)

This module monitors several of the compressor safeties and controls four of the outputs used to control the compressor. The CPM monitors compressor current, compressor voltage, high pressure switch status, and compressor motor temperature. It controls the compressor contactor oil solenoid, motor cooling solenoid, and star delta transition relay. Each CPM sends the PSIO its circuit motor temperature, alarm status and the output status of the module.

The CPM provides the following functions:

- Compressor main contactor control
- Star delta contactor transition
- Compressor ground current protection
- Reads motor temperature
- High-pressure protection
- Reverse rotation protection
- Voltage imbalance protection
- Current imbalance protection
- Compressor oil solenoid control
- Motor cooling solenoid control
- Sensor bus communications
- Starting and running overcurrent protection

The CPM has four output relays and four inputs.

## OUTPUTS:

- Compressor contactor
- Compressor oil solenoid
- Compressor motor cooling solenoid
- Star delta transition relay

## INPUTS:

- Motor temperature
- 3-phase voltage
- 3-phase current
- High pressure switch

A diagram of the CPM board is shown below. There are line voltage inputs at L1, L2 and L3. Next to these inputs are the current toroid inputs at plug 1. Next to plug 1 are the three COMM3 communication terminals. In the lower right corner of the board are the inputs for motor winding temperature. The address dip switch and compressor Must Trip Amps header are factory set.

On the board, at the top left is a 9-pin plug 2, where power is supplied to the board and where the outputs loads are connected. To verify proper Must Trip Amps header configuration, press <1> <SRVC> and use the  key on the HSIO II.

### Compressor Protection Module (CPM)

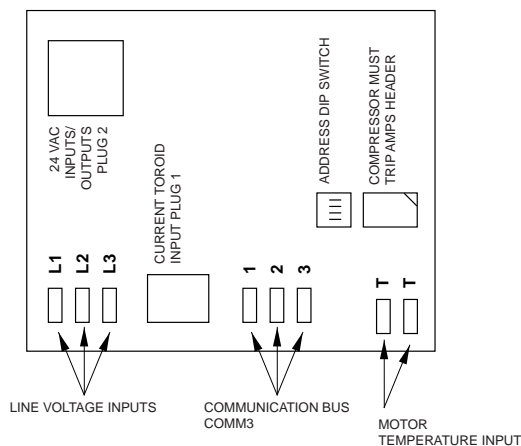

COMPRESSOR PART NUMBER	Tons	MTA	Compressor MTA Header Configuration
06NW 1146 S7 N	39	81	00010000
06NW 1174 S7 N	46	99	00011000
06NW 1209 S7 N	56	119	00100011
06NW 1250 S7 N	66	143	00101110
06NW 1300 S5 N	80	174	00111110
06NW 1209 S7 E	56	130	00101000
06NW 1250 S7 E	66	156	00110101
06NW 1300 S5 E	80	189	01000110
06NA 1146 S7 N	39	119	00100011
06NA 1174 S7 N	46	145	00110000
06NA 1209 S7 N	56	175	00111111
06NA 1146 S7 E	39	134	00101010
06NA 1174 S7 E	46	163	00111000
06NA 1209 S7 E	56	195	01001000
06NA 1250 S7 E	66	236	01011101
06NA 1300 S5 E	80	293	01111010

#### Legend:

<b>MTA</b>	Compressor Must Trip Amps
<b>N</b>	Non Economized compressor
<b>E</b>	Economized compressor
<b>06NW</b>	Water-cooled condensing compressor
<b>06NA</b>	Air-cooled condensing compressor

#### Header configuration:

- 0** broken jumper from left to right
- 1** existing jumper from left to right

The CPM communicates on the COMM3 communication bus to the PSIO module. Proper operation of the CPM board can be verified by observing the three LED's located on the board. The left LED is red and blinks to indicate that the module is powered and operating correctly. The middle LED is yellow and blinks when there is an automatic reset alarm condition. The yellow LED will remain on and will not blink for manual reset alarm conditions. The right LED is green and will blink when the module is satisfactorily communicating with the PSIO module. The CPM communicates the status of its inputs, outputs and reports different alarm conditions to the PSIO. The alarms are listed in table below:

### Compressor protection module code table

Condition	Value
High pressure switch trip	1.0
No motor current	2.0
Current imbalance warning 10 %	2.5
Current imbalance alarm 10 %	2.7
Current imbalance 18 %	3.0
Single phase current loss	3.5
High motor current	4.0
Ground fault	5.0
Voltage imbalance warning 3 %	5.5
Voltage imbalance alarm 3 %	5.7
Voltage imbalance 7 %	6.0
Single phase voltage loss	6.5
Voltage phase reversal	7.0
Contact failure	7.5
Current phase reversal	8.0
Motor over temperature	8.5
Open thermistor	9.0
Configuration header fault	9.5
Shorted thermistor	10.0
No Error	0

#### **WARNING**

*The CPM module has many features that were specifically designed to protect the compressor including reverse rotation protection. Do not attempt to bypass or alter any of the factory wiring. Any compressor operation in the reverse direction will result in a compressor failure that will require replacement.*

The PSIO will generate an alert when it receives an alarm input from the CPM. The alert will be generated in a y.xx format where "y" refers to the compressor and "xx" to the alarm value. For example, the HSIO II would display Alert 1.65 for a single phase voltage loss occurring on compressor A1. Similarly, the display would read 5.85 for a motor over-temperature condition on compressor B1.

The high-pressure switch is wired in series with the relay coils of the four relays on the CPM. If this switch opens during operation, all relays on the CPM will be de-energized and the compressor stopped. The failure is reported to the PSIO and the processor module will lock off the compressor from restarting until the alarm is manually reset.

### Keypad and Display Module (HSIO II)

This device consists of a keypad with 8 function keys, 4 operative keys, 12 numeric keys, and a 2 line-24 character alphanumeric LCD (liquid crystal display). Key usage is explained in the Control Operation section.

#### Keypad and display module

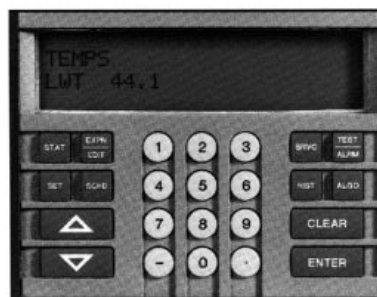

## CONTROL OPERATION

### Keypad and display module usage (HSIO II)

FUNCTION KEYS	USE	OPERATIVE KEYS	USE
<STAT>	STATUS - For displaying diagnostic codes and current operating information about the machine.	<EXPN/EDIT>	EXPAND - For displaying a non-abbreviated expansion of the display.
<HIST>	HISTORY - For displaying run time, cycles and previous alarms.	<CLEAR>	CLEAR - For clearing the screen of all displays.
<SRVC>	SERVICE - For entering specific unit configuration and enabling manual control function.	<↑>	UP ARROW - For returning to previous display position.
<SCHD>	SCHEDULE - For entering occupied/unoccupied schedules for unit operation.	<↓>	DOWN ARROW - For advancing to next display position.
<SET>	SET POINT - For entering operating set points and day/ time information.	<ENTER>	ENTER - For entering data
<TEST/ALARM>	TEST - For testing operating of the analogue and discrete outputs.		

#### Automatic default display

When the keypad has not been used for 10 minutes, the display automatically switches to the rotating automatic default display. This display contains the five parts shown below:

Entering fluid temperature	xx.x °C
Leaving fluid temperature	xx.x °C
Percent total capacity	xxx.x %
Total number of alarms	xx
MODES: MODE_TBL	current active modes

All functions are made up of a group of subfunctions. To enter a subfunction, first press subfunction number desired. Then press the function key in which the subfunction resides. To move within that subfunction, press the up or down arrow keys.

- 1 - At any time, another subfunction may be entered by pressing the subfunction number, then the function key.
- 2 - Prior to starting unit, check leaving fluid set point for correct setting. Refer to Set Point Function section.
- 3 - Depending on system configuration, all displays may not be shown

### Functions and subfunctions

SUB FUNCTION NO.	FUNCTIONS					
	Status <STAT>	Test <TEST>	Schedule <SCHD>	Service <SRVC>	History <HIST>	Set Point <SET>
1	Alarm Display	Circuit A Discrete Outputs	Ice Build Occupancy Schedule	Factory Configuration	Operating Hours	Set Points
2	General Parameters Display	Circuit B Discrete Outputs	Local/Normal Occupancy Schedule	Options Configuration 1	Alarm History	English/Metric
3	Circuit A Analogue Values	Unit Discrete Outputs	Remote CCN Occupancy Schedule	Options Configuration 2		Bus Address
4	Circuit A Discrete Inputs Outputs Table	Valves and Motor Master	Holiday 01 Configuration	Reset/Demand Limit Configuration		Time/Date Configuration
5	Circuit B Analogue Values		Holiday 02 Configuration	Machine Configuration Codes		CCN Enable/Disable
6	Circuit B Discrete Inputs Outputs Table		Holiday 03 Configuration			
7	Unit Analogue Parameters		Holiday 04 Configuration	Transducer Calibration		
8	Miscellaneous Inputs/Outputs		Holiday 05 Configuration	Manual Control		
9	Operating Modes		Holiday 06 Configuration			
10	Capacity Control		Holiday 07 Configuration**			

**Note:**

\*\* Subfunction <11> through <33> <SCHD> are for configuration Holidays 08-30.

## Accessing functions and subfunctions

OPERATION	KEYPAD ENTRY	DISPLAY RESPONSE
To access a function, press subfunction no. and function name key. Display shows subfunction group	<1> <TEST>	Circuit A Discrete Outputs  Loader A1 Relay is OFF
To move to other elements, scroll up or down using arrow keys.	<↓>	Loader A2 Relay is OFF
	<↓>	Hot Gas Bypass Valve A Relay is OFF
	<↓>	Circuit A Oil Heater Relay is OFF
	<↓>	A1 Mtr. Cooling Solenoid Relay is OFF
	<↓>	A2 Mtr. Cooling Solenoid Relay is OFF
	<↓>	Circuit A Oil Pump Relay is OFF
	<↓>	Oil Solenoid A1 Relay is OFF
When the last element in a subfunction has been displayed, the first element is repeated.	<↓>	Oil Solenoid A2 Relay is OFF
	<↓>	Loader A1 Relay is OFF
To move to next subfunction It is not necessary to use subfunction number. Press function name key to advance display through all subfunctions within a function and then back to the first.	<TEST>	Circuit B Discrete Outputs  Loader B1 Relay is OFF
	<TEST>	Unit Discrete Outputs
	<TEST>	Valves and Motor Master Circuit A Discrete Outputs
To move to another function, either depress function name key for desired function (display shows the first subfunction). or Access a specific subfunction by using the subfunction number and the function name key.	<STAT>	Alarms: XX Reset Alarms: 1 <ENTER>
	<4> <STAT>	CIR. A DISCRETE OUTPUTS

### GENERAL REMARK

*Screw chiller PIC control software is capable of controlling water-cooled and air-cooled units with dual independent refrigerant circuits. Circuits are identified as circuits A and B. These may be equipped with 1 or 2 compressors per circuit. A1 and A2 compressors are dedicated for circuit A. B1 and B2 compressors are dedicated for circuit B. In Status and History functions, only the compressor information for existing compressors will be displayed.*



## Status function

This function shows the rotating display, current status of alarm and alert (diagnostic) codes, capacity stages, operating modes, chilled water setpoint, all measure system temperatures and pressures, analog inputs, and switch inputs.

### Alarms/Alerts

Alarms and alerts are messages that indicate that one or more faults have been detected. See Table for definitions. The alarms and alerts indicate failures that cause the unit to shut down, terminate an option (such as reset) or result in the use of a default value as set point.

Up to 10 alarms/alerts can be stored at once. To view them press <1> <STAT>. The control will display the current total number of alarms/alerts. Use the arrow keys to scroll through the list. Depress the <EXPN> key when needed to view the full description of an alarm or alert. Press <1> <ENTR> to clear all the alarms. When an alarm or alert is stored in the display and the machine automatically resets, the alarm/alert is deleted. Codes for safeties which do not automatically reset are not deleted until the problem is corrected and the machine is switched to the OFF position, then back to LOCAL/REMOTE or under CCN control. To clear manual reset alarms from the CPM control modules, the control circuit breaker must be switched off, then back on.

### General parameters

General operating parameters are displayed including control mode, run status, CCN status and the five most current alarms. Press <2> <STAT> to display these and the other values as shown in status function and subfunctions table.

### Circuit A and B analogue and discrete information

Circuit A analogue values can be viewed by pressing <3> <STAT> and scrolling down to see current system operating conditions such as pressures and temperatures. Pressing <4> <STAT> will bring up Circuit A Discrete Inputs and outputs. Scroll down to view the On/Off status of the compressor(s), loaders, solenoids and pumps. Oil switch and feedback inputs are also displayed. Press <5> and <6> <STAT> to view the identical analogue values and discrete inputs and outputs for Circuit B. See status function and subfunctions table for a complete display.

### Unit analogue parameters and temperature reset

Press the <7> and <STAT> keys and scroll down to display the unit entering and leaving fluid temperatures as well as the temperature reset signal and calculated values.

### Miscellaneous Inputs and Outputs

Pressing <8> <STAT> and scrolling down will display the demand limit settings, pump relay and switch status and miscellaneous items such as Heat/Cool and Dual Setpoint switch positions. See status function and subfunctions table for a complete list.

### Modes

The operating modes are displayed to indicate the operating status of the unit at a given time. See status function and subfunctions table for a complete list of all modes.

To enter the MODES subfunction, press <9> <STAT> and use the <↓> key to view all current modes of operation.

## Capacity Control

Pressing <10> <STAT>, this subfunction displays the load/unload factor, control point and leaving water temperature. Scrolling down will also reveal the liquid level sensor values in degrees format.

STATUS			
SUBFUNCTION	KEYPAD ENTRY	DISPLAY	COMMENT
1 Alarms	<1>	Alarm: xx	
	<STAT>	Reset Alarms: 1 <ENTER>	
	<↓>	Scroll down to display all current alarms. Use EXPN key when needed.	
2 General Parameters	<2>	General parameters	
	<STAT>		
	<↓>	Control Mode	Displays LOCAL ON/OFF or CCN ON/OFF
	<↓>	Run Status	Displays Off/On
	<↓>	Occupied ?	Displays Yes/No
	<↓>	CCN Enable	Displays Off/On
	<↓>	CCN Chiller Start/Stop	Displays Start/Stop
	<↓>	Alarm State	Displays Normal/Alarm
	<↓>	Current Alarm 1	Displays x.xx
	<↓>	Current Alarm 2	Displays x.xx
	<↓>	Current Alarm 3	Displays x.xx
	<↓>	Current Alarm 4	Displays x.xx
	<↓>	Current Alarm 5	Displays x.xx
	<↓>	Active Demand Limit	Displayed as xxx.x %
	<↓>	Percent Total Capacity	Displayed as xxx.x %
	<↓>	Water/Brine Setpoint	Displayed as xx.x °C
	<↓>	Control Point	Displayed as xx.x °C
	<↓>	Entering Fluid Temperature	Displayed as xx.x °C
	<↓>	Leaving Fluid Temperature	Displayed as xx.x °C
	<↓>	Emergency Stop	Displayed Emstop
<↓>	Minutes Left for Start	Displayed as xx min	
<↓>	Heat-Cool Status	Displayed Heat/Cool	
3 Circuit A Analogue Values	<3>	Circuit A analogue VALUES	
	<STAT>		
	<↓>	Total Capacity	Displayed as xxx.x %
	<↓>	Available Capacity	Displays xxx.x %
	<↓>	Discharge Pressure	Displays xxx.x kPa
	<↓>	Suction Pressure	Displays xxx.x kPa
	<↓>	A1 Oil Pressure Diff.	Displays xxx.x kPa
	<↓>	A2 Oil Pressure Diff.	Displays xxx.x kPa
	<↓>	A1 Oil Pressure	Displays xxx.x kPa
	<↓>	A2 Oil Pressure	Displays xxx.x kPa
	<↓>	Discharge Gas Temperature	Displays xxx.x °C
	<↓>	A1 Motor Temperature	Displays xxx.x °C
	<↓>	A2 Motor Temperature	Displays xxx.x °C
	<↓>	SAT Condensing Temp	Displays xxx.x °C
	<↓>	Saturated Suction Temp	Displays xxx.x °C
	<↓>	EXV Percent Open	Displays xxx.x %
	<↓>	Motormaster Speed	Displays xxx.x %
	<↓>	Water Valve Position	Displays xxx.x %
	<↓>	Cooler Level Indicator	Displays xxx.x
	<↓>	CPM A1 Feedback	Displays x.x Volts
<↓>	CPM A2 Feedback	Displays x.x Volts	
<↓>	Circuit A Econ Pressure	Displays xxx.x kPa	

STATUS (CONT.)			
SUBFUNCTION	KEYPAD ENTRY	DISPLAY	COMMENT
4 Circuit A discrete Outputs	<4><STAT>	CIR. A DISCRETE OUTPUTS	
	<↓>	Compressor A1	Displays Off/On
	<↓>	Compressor A2	Displays Off/On
	<↓>	Loader A1	Displays Off/On
	<↓>	Loader A2	Displays Off/On
	<↓>	Hot Gas Bypass Valve A	Displays Off/On
	<↓>	Circuit A Oil Heater	Displays Off/On
	<↓>	A1 Mtr Cooling Solenoid	Displays Off/On
	<↓>	A2 Mtr Cooling Solenoid	Displays Off/On
	<↓>	Circuit A Oil Pump	Displays Off/On
	<↓>	Oil Solenoid A1	Displays Off/On
	<↓>	Oil Solenoid A2	Displays Off/On
		CIR. A DISCRETE INPUTS	
	<↓>	Circuit A Oil Switch	Displays Open/Close
	<↓>	Compressor A1 Feedback	Displays Off/On
	<↓>	Compressor A2 Feedback	Displays Off/On
5 Circuit B Analogue Values	<5><STAT>	CIRCUIT B ANALOGUE VALUES	
	<↓>	Total Capacity	Displayed as xxx.x%
	<↓>	Available Capacity	Displays as xxx.x%
	<↓>	Discharge Pressure	Displays xxx.x KPa
	<↓>	Suction Pressure	Displays xxx.x KPa
	<↓>	B1 Oil Pressure Diff.	Displays xxx.x KPa
	<↓>	B2 Oil Pressure Diff.	Displays xxx.x KPa
	<↓>	B1 Oil Pressure	Displays xxx.x KPa
	<↓>	B2 Oil Pressure	Displays xxx.x KPa
	<↓>	Discharge Gas Temperature	Displays xxx.x °C
	<↓>	B1 Motor Temperature	Displays xxx.x °C
	<↓>	B2 Motor Temperature	Displays xxx.x °C
	<↓>	SAT Condensing Temp	Displays xxx.x °C
	<↓>	Saturated Suction Temp	Displays xxx.x °C
	<↓>	EXV Percent Open	Displays xxx.x %
	<↓>	Motormaster Speed	Displays xxx.x %
	<↓>	Cooler Level Indicator	Displays xxx.x
	<↓>	CPM B1 Feedback	Displays x.x Volts
	<↓>	CPM B2 Feedback	Displays x.x Volts
	<↓>	Circuit B Econ Pressure	Displays xxx.x KPa
6 Circuit B discrete Outputs	<6><STAT>	CIR. B DISCRETE OUTPUTS	
	<↓>	Compressor B1	Displays Off/On
	<↓>	Compressor B2	Displays Off/On
	<↓>	Loader B1	Displays Off/On
	<↓>	Loader B2	Displays Off/On
	<↓>	Hot Gas Bypass Valve B	Displays Off/On
	<↓>	Circuit B Oil Heater	Displays Off/On
	<↓>	B1 Mtr Cooling Solenoid	Displays Off/On
	<↓>	B2 Mtr Cooling Solenoid	Displays Off/On
	<↓>	Circuit B Oil Pump	Displays Off/On
	<↓>	Oil Solenoid B1	Displays Off/On
	<↓>	Oil Solenoid B2	Displays Off/On
		CIR. B DISCRETE INPUTS	
	<↓>	Circuit B Oil Switch	Displays Open/Close
	<↓>	Compressor B1 Feedback	Displays Off/On
	<↓>	Compressor B2 Feedback	Displays Off/On

**Legend**  
CCN: Carrier Comfort Network  
EXV: Electronic Expansion Valve  
CPM: Compressor Protection Module

STATUS (CONT.)			
SUBFUNCTION	KEYPAD ENTRY	DISPLAY	COMMENT
7 Unit Analogue Parameters	<7><STAT>	UNIT ANALOGUE PARAMETERS	
	<↓>	Cooler Entering Fluid	Displays xx.x °C
	<↓>	Cooler Leaving Fluid	Displays xx.x °C
	<↓>	Condenser Entering Fluid	Displays xx.x °C
	<↓>	Condenser Leaving Fluid	Displays xx.x °C
	<↓>	Reclaim Entering Fluid	Displays xx.x °C
	<↓>	Reclaim Leaving Fluid	Displays xx.x °C
	<↓>	5 Volt Supply	Displays x.x Volt
		TEMPERATURE RESET	
	<↓>	4-20 mA Reset Signal	Displays xx.x mA
	<↓>	Return Reset Signal	Displays xx.x °C
	<↓>	Exterminal Reset Signal	Displays xx.x °C
	<↓>	Outdoor Air Temp	Displays xx.x °C
	<↓>	Calculated Reset	Displays xx.x °C
8 Misc. Inputs/Outputs	<8><STAT>	MISC. INPUT/OUTPUTS	
	<↓>	Fan 1	Displays on/off
	<↓>	Fan 2	Displays on/off
	<↓>	Fan 3	Displays on/off
	<↓>	Fan 4	Displays on/off
	<↓>	Fan 5	Displays on/off
	<↓>	Fan 6	Displays on/off
		DEMAND LIMIT	
	<↓>	4-20 mA Demand Signal	Displays xx.x mA
	<↓>	Demand Switch 1	Displays Off/On
	<↓>	Demand Switch 2	Displays Off/On
	<↓>	CCN Loadshed Signal	Displays Normal
	<↓>	Max Allowable CAP	Displays xxx.x %
		PUMPS	
	<↓>	Cooler Pump Relay	Displays Off/On
	<↓>	Cooler Pump Flow Switch	Displays Off/On
	<↓>	Condenser Pump Relay	Displays Off/On
	<↓>	Condenser Pump Flow Switch	Displays Off/On
		MISCELLANEOUS	
	<↓>	Ice Valve	Displays Off/On
	<↓>	Ice Build Complete	Displays Yes/No
	<↓>	Heat/Cool Switch	Displays Heat/Cool
	<↓>	Dual Setpoint Switch	Displays Off/On
	<↓>	Cooler Heater	Displays Off/On
	<↓>	Options Temperature 1	Displays xx.x °C
	<↓>	Options Temperature 2	Displays xx.x °C
9 Operating Modes	<9><STAT>	MODES MODE TBL	
		mode name on/off	Only active modes displayed
	<↓>	LOCAL OFF	
	<↓>	CCN OFF	
	<↓>	CLOCK OFF	
	<↓>	LOCAL ON	
	<↓>	CCN ON	
	<↓>	CLOCK ON	
	<↓>	DUAL SP ACTIVE (1st SP)	
	<↓>	DUAL SP ACTIVE (2nd SP)	
	<↓>	TEMPERATURE RESET	
	<↓>	ACTIVE	
	<↓>	DEMAND LIMIT ACTIVE	
	<↓>	LOAD LIMIT ACTIVE	
	<↓>	LOW SOURCE TEMP	
	<↓>	PROTECT	
	<↓>	RAMP LOADING ACTIVE	
	<↓>	TIMED OVERRIDE ACTIVE	
	<↓>	LOW COOLER SUCTION TEMP	
	<↓>	WSM CONTROLLING	
	<↓>	SLOW CHANGE OVERRIDE	
	<↓>	OFF TO ON DELAY ACTIVE	
	<↓>	FSM CONTROLLING	
	<↓>	2 CHILLR LEAD LAG ACTIVE	

STATUS (CONT.)			
SUBFUNCTION	KEYPAD ENTRY	DISPLAY	COMMENT
	<↓>	2 CHLLR COMM FAILURE	
	<↓>	CIR A LOW DISCHG SUPERHT	
	<↓>	CIR B LOW DISCHG SUPERHT	
	<↓>	CIR A HIGH SDT	
	<↓>	CIR B HIGH SDT	
10 Capacity Control	<10><STAT>	CAPACITY CONTROL	
	<↓>	Load/Unload Factor	Displays xxx.x %
	<↓>	Control Point	Displays xx.x °C
	<↓>	Leaving Water Temp	Displays xx.x °C
	<↓>	MISC. INDICATORS	
	<↓>	Liquid Lvl Sensor Cir. A	Displays xx.x °C
	<↓>	Liquid Lvl Sensor Cir. B	Displays xx.x °C

## Test function and subfunctions

The test function operates the diagnostic program. To initiate the test function, the LOCAL/OFF/REMOTE switch must be in the OFF position.

To reach a particular test, press its subfunction number followed by the Enter key then scroll to the desired test by pressing the down arrow key.

TEST			
SUBFUNCTION	KEYPAD ENTRY	DISPLAY	COMMENT
1 Circuit A Discrete Output	<1><TEST>	CIRCUIT A DISCRETE OUTPUT	
	<↓>	Loader A1 relay is OFF	
	<1><ENTR>	Loader A1 relay is ON	
	<↓>	Loader A2	Similarly, use <1><ENTR> to test remaining outputs. Press the down arrow key or <0><ENTR> to turn an output off.
	<↓>	Minimum load Valve A	
	<↓>	Circuit A Oil Heater	
	<↓>	A1 Mtr. Cooling Solenoid	
	<↓>	A2 Mtr. Cooling Solenoid	
	<↓>	Circuit A Oil Pump	
	<↓>	Oil Solenoid A1	
	<↓>	Oil Solenoid A2	
			*Output will display Relay is ABSENT when not configured
2 Circuit B Discrete Output	<2><TEST>	CIRCUIT B DISCRETE OUTPUT	
	<↓>	Loader B1 relay is OFF	
	<1><ENTR>	Loader B1 relay is ON	
	<↓>	Loader B2	Similarly, use <1><ENTR> to test remaining outputs. Press the down arrow key or <0><ENTR> to turn the output off.
	<↓>	Minimum load Valve B	
	<↓>	Circuit B Oil Heater	
	<↓>	B1 Mtr. Cooling Solenoid	
	<↓>	B2 Mtr. Cooling Solenoid	
	<↓>	Circuit B Oil Pump	
	<↓>	Oil Solenoid B1	
	<↓>	Oil Solenoid B2	
			*Output will display Relay is ABSENT when not configured

TEST (CONT.)			
SUBFUNCTION	KEYPAD ENTRY	DISPLAY	COMMENT
3 Unit Discrete Output	<3><TEST>	UNIT DISCRETE OUTPUT.	
	<↓>	Fan 1	
	<↓>	Fan 2	
	<↓>	Fan 3	
	<↓>	Fan 4	
	<↓>	Fan 5	
	<↓>	Fan 6	
	<↓>	Cooler Pump	Similarly, use
	<↓>	Condenser Pump	<1><ENTR> to test
	<↓>	Cooler Heater	remaining outputs.
	<↓>	Alarm	Press the down
	<↓>	Remote Alarm 1	arrow key or
	<↓>	Remote Alarm 2	<0><ENTR> to turn
	<↓>	Remote Alarm 3	an output off.
	<↓>	Remote Alarm 4	
	<↓>	Remote Alarm 5	
	<↓>	Remote Alarm 6	
	<↓>	Remote Alarm 7	
	<↓>	Remote Alarm 8	
	<↓>	Remote Alarm 9	
	<↓>	Remote Alarm 10	
	<↓>	Remote Alarm 11	
	<↓>	Remote Alarm 12	
	<↓>	Remote Alarm 13	
	<↓>	Remote Alarm 14	*Output will display
	<↓>	Remote Alarm 15	Relay is ABSENT
	<↓>	Remote Alarm 16	when not configured

TEST (CONT.)			
SUBFUNCTION	KEYPAD ENTRY	DISPLAY	COMMENT
4 Valves and Motor Master	<4><TEST>	VALVES AND MOTOR MASTER	
	<↓>	Circuit A EXV Valve Target Percent = 0 %	
	<1><ENTR>	CIRCUIT A EXV VALVE Target Percent = 25 %	Step in 25% increments. EXV may be moved to a specific percent by entering the desired value and pressing <ENTR>. Wait 30 seconds between each step for valve to stop moving.
	<1><ENTR>	CIRCUIT A EXV VALVE Target Percent = 50 %	Valve may be closed in 25% increments by keying in <0><ENTR>. Wait 30 seconds between each step for valve to stop moving.
	<1><ENTR>	CIRCUIT A EXV VALVE Target Percent = 75 %	
	<1><ENTR>	CIRCUIT A EXV VALVE Target Percent = 100 %	
	<↓>	Circuit B Water Valve	Test same method as for Circuit A.
	<5><0><ENTR>	CIRCUIT A WATER VALVE Target Percent = 50 %	Test same method as for EXV valves.
	<↓>	Circuit A% Fan Speed	Test same method as for EXV valves.
	<↓>	Circuit B% Fan Speed	Test same method as for EXV valves.

## Schedule function

The schedule function key is used to configure the occupancy schedule.

This function provides a means to automatically switch the chiller from an occupied mode to an unoccupied mode.

The schedules consist of eight user-configurable occupied time periods. The control supports time schedules for local control, remote control and ice building. These time periods can be flagged to be in effect or not in effect on each day of the week and for holidays (30 days).

Ice build control automatically sets the chilled water/brine control point of the machine to a temperature where an ice building operation for thermal storage can be accomplished.

## Service function

This function allows the technician to view and input configuration data. Factory configuration data (subfunction 1) cannot be modified.

Options configuration 1 and 2 (subfunctions 2 & 3) as well as all the other subfunctions, reset/demand limit (subfunction 4), factory configuration codes (subfunction 5), transducer calibration (subfunction 7), manual control (subfunction 8) will need a password to be entered.

The use of the service function is reserved to the Carrier service personal only.

SERVICE			
SUBFUNCTION	KEYPAD ENTRY	DISPLAY	COMMENT
1 Service Configuration	<1><SRVC>	SOFTWARE CESR 500100 Ver. xxx	
	<↓>	Unit Type x	1 = Air-cooled, 2 = Water-cooled 3 = Split system
	<↓>	Number of Cir A Comp x	
	<↓>	Compressor A1 Tonnage xx	
	<↓>	Compress A2 Tonnage xx	
	<↓>	Capacity high temperature override x	0 = Disabled 1 = Enabled
	<↓>	Number of Cir B Comp x	
	<↓>	Compressor B1 Tonnage xx	
	<↓>	Compressor B2 Tonnage xx	
	<↓>	Max. Cond. Temp Setpoint xxx.x °C	30GX = 70°C 30HXA = 70°C 30HXC = 50°C
	<↓>	MOP Setpoint xx.x °C	Default = 11.1°C
	<↓>	Fan Staging Select x	Displays Not Used or a number
	<↓>	CPM Board Used? Yes	
	<↓>	Compr. A1 Must Trip Amps xxx.x	Verify with Compressor Electrical Data
	<↓>	Compr. A2 Must Trip Amps xxx.x	Verify with Compressor Electrical Data
	<↓>	Compr. B1 Must Trip Amps xxx.x	Verify with Compressor Electrical Data
	<↓>	Compr. B2 Must Trip Amps xxx.x	Verify with Compressor Electrical Data
2 Options Configuration 1	<2><SRVC>	COOLER FLUID SELECT	1 = Water (Default), 2 = Medium Temp brine 3 = Low Temp Brine (HX only).
	<↓>	Min. Load Valve Select x	Displays Enable Disable Default: Disable.
	<↓>	Loading Sequence Select x	1 = Equal circuit. 2 = Staged circuit Default: 1
	<↓>	Lead/Lag Sequence Select x	1 = Automatic (Default), 2 = Circuit A leads, 3 = Circuit B leads
	<↓>	Head Press. Control Type x	0 = None (Default), 1 = Air cooled, 2 = Water cooled, 3 = Fixed air cooled
	<↓>	Motormaster Select x	0 = None (Default), 1 = Direct control

SERVICE (CONT.)			
SUBFUNCTION	KEYPAD ENTRY	DISPLAY	COMMENT
	<↓>	Water Valve Type	0 = None (Default), 1 = 4-20 mA, 2 = 0-10 V, 3 = 20-4 mA, 4 = 10-0 V
	<↓>	Ext. Reset Sensor Select	0 = Space Temp. Thermistor (Default)
	x		1 = outside air thermistor
	<↓>	Cooler Pump Interlock	0 = No interlock
	x		1 = Interlock enabled (Default)
	<↓>	Cooler Pump Control	0 = Not controlled (Default)
	x		1 = On/Off Control
	<↓>	Condenser Pump Control	0 = Not controlled (Default)
	x		1 = On/Off Control 2 = Off when Stages = 0
	<↓>	Condenser Flow Switch	Displays Enable/Disable
	x		Default: Disable
	<↓>	Condenser Water Sensors	0 = Not used (Default)
	x		1 = Used
	<↓>	Heat Reclaim Sensors	0 = Not used (Default)
	x		1 = Used
3 Options	<3> <SRVC>	OPTIONS 2	
Configuration 2	<↓>	Cooling Setpoint Select	0 = Single setpoint (Default)
	x		1 = Dual Setpoint (switch controlled) 2 = Dual Setpoint (clock controlled)
	<↓>	Heating Setpoint Select	0 = Single setpoint (Default)
	x		1 = Dual Setpoint (switch controlled) 2 = Dual Setpoint (clock controlled)
	<↓>	Ramp Load Select	0 = Disabled
	x		1 = Enabled (Default)
	<↓>	Clock Control Select	0 = No clock control (Default)
	x		1-64 = Local clock control
	<↓>	Ice Configuration Select	0 = No clock control (Default)
	x		1-64 = Local clock control
	<↓>	OAT Sensor Select	0 = Disabled, 1 = Enabled
	x		Default: 0
	<↓>	Remote Alarm Select	0 = Disabled, 1 = Enabled
	x		Default: 0
	<↓>	Alarm Reset Select	0 = Not Selected (Default)
	x		1 = Selected (Allows use of LOR switch to reset alarms)
	<↓>	Close Control Select	0 = Disabled, 1 = Enabled
	x		Default: 0
	<↓>	Dead Band Multiplier	Default: 1.0
	x.x		
	<↓>	Current Unbalance Alarm	0 = Disabled, 1 = Enabled
	x		Default: 1
	<↓>	Voltage Unbalance Alarm	0 = Disabled, 1 = Enabled
	x		Default: 1

SERVICE (CONT.)			
SUBFUNCTION	KEYPAD ENTRY	DISPLAY	COMMENT
4 Reset	<4> <SRVC>	COOLING RESET TYPE 1	
Configuration table	<↓>	Degrees reset at 20 mA xx.x dC	
	<↓>	COOLING RESET TYPE 2	
	<↓>	Remote temp = no reset xx.x dC	
	<↓>	Remote temp = full reset xx.x dC	
	<↓>	Degrees reset xx.x dC	
	<↓>	COOLING RESET TYPE 3	
	<↓>	CHW ΔT = no reset xx.x dC	
	<↓>	CHW ΔT = full reset xx.x dC	
	<↓>	Degrees reset xx.x dC	
	<↓>	COOLING RESET	
	<↓>	Select/enable reset type x	0 = no reset 1 = 4-20 mA reset 2 = external reset 3 = return fluid reset
	<↓>	HEATING RESET TYPE 1 xx.x dC	
	<↓>	HEATING RESET TYPE 2	
	<↓>	Remote temp = no reset xx.x dC	
	<↓>	Remote temp = full reset xx.x dC	
	<↓>	Degrees reset xx.x dC	
	<↓>	HEATING RESET TYPE 3	
	<↓>	HTW ΔT = no reset xx.x dC	
	<↓>	HTW ΔT = full reset xx.x dC	
	<↓>	Degrees reset xx.x dC	
	<↓>	HEATING RESET	
	<↓>	Select/enable reset type x	0 = no reset 1 = 4-20 mA reset 2 = external reset 3 = return fluid reset
	<↓>	DEMAND LIMIT	
	<↓>	Demand limit at 20 mA xxx.x %	Enter 0-100 %
	<↓>	Demand limit select x	0 = none 1 = two step switch 2 = 4-20 mA 3 = CCN loadshed
	<↓>	Loadshed group No. x	0-99
	<↓>	Loadshed demand delta xxx %	0-60 %
	<↓>	Max. loadshed time xx min	0-120 min
	<↓>	WATER VALVE PID	
	<↓>	Proportional PID gain x.x	Default = 1.0 Adjustable from - 20.0 to 20.0
	<↓>	Integral PID gain x.x	Default = 1.0 Adjustable from - 20.0 to 20.0
	<↓>	Derivative PID gain x.x	Default = 1.0 Adjustable from - 20.0 to 20.0
	<↓>	AIR MOTORMASTER PID	
	<↓>	Proportional PID gain x.x	Default = 1.0 Adjustable from - 20.0 to 20.0
	<↓>	Integral PID gain x.x	Default = 1.0 Adjustable from - 20.0 to 20.0
	<↓>	Derivative PID gain x.x	Default = 1.0 Adjustable from - 20.0 to 20.0

SERVICE (CONT.)			
SUBFUNCTION	KEYPAD ENTRY	DISPLAY	COMMENT
5 Factory Configuration codes	<5> <SRVC>	COOLING RESET TYPE 1	
	<↓>	Configuration code 1 xxxxxxx	Factory set
	<↓>	Configuration code 2 xxxxxxx	Factory set
	<↓>	Configuration code 3 xxxxxxx	Factory set
	<↓>	SERVICE CODES	
	<↓>	Configuration code 4 xxxxxxx	Factory set
	<↓>	Configuration code 5 xxxxxxx	Factory set

6 NOT USED

7 Transducer calibration	<7> <SRVC>	CALIBRATION OFFSET	
	<↓>	CIRCUIT A PRESSURE	
	<↓>	Discharge pressure xxx.x kPa	
	<↓>	Suction pressure xxx.x kPa	
	<↓>	A1 oil pressure xxx.x kPa	
	<↓>	A2 oil pressure xxx.x kPa	
	<↓>	Economizer pressure xxx.x kPa	
	<↓>	CALIBRATION OFFSET	
	<↓>	CIRCUIT B PRESSURE	
	<↓>	Discharge pressure xxx.x kPa	
	<↓>	Suction pressure xxx.x kPa	
	<↓>	B1 oil pressure xxx.x kPa	
	<↓>	B2 oil pressure xxx.x kPa	
	<↓>	Economizer pressure xxx.x kPa	
	<↓>	Calibrate all at 0 kPa Yes/No	
	<↓>	Last calibration date mmm dd - yy	

8 Manual control table	<8> <SRVC>	Manual control enable Ddisable	LOR switch should be in OFF position
	<1> <ENTR>	Password protected Enter:	Will be displayed if not entered earlier in current HSIO use
	<1111> <ENTR>	Manual control enable Ddisable	
	<1> <ENTR>	Manual control enable Enable	Switch LOR switch to local before proceeding
	<↓>	Circuit A compressor 1 Off	
	<↓> <1> <ENTR>	Circuit A compressor 1 On	Provided no alarms exist, control will attempt circuit start within 2 minutes. Press <0> <ENTR> to stop circuit
	<↓>	Circuit A compressor 2 Off	<1> <ENTR> to enable, <0> <ENTR> to stop
	<↓>	Circuit A loader 1 Off	<1> <ENTR> to enable, <0> <ENTR> to stop
	<↓>	Circuit A loader 2 Off	<1> <ENTR> to enable, <0> <ENTR> to stop
	<↓>	Circuit A hot gas bypass Off	<1> <ENTR> to enable, <0> <ENTR> to stop
	<↓>	Circuit B compressor 1 Off	<1> <ENTR> to enable, <0> <ENTR> to stop

SERVICE (CONT.)			
SUBFUNCTION	KEYPAD ENTRY	DISPLAY	COMMENT
	<↓>	Circuit B compressor 1 Off	<1> <ENTR> to enable, <0> <ENTR> to stop
	<↓>	Circuit B loader 1 Off	<1> <ENTR> to enable, <0> <ENTR> to stop
	<↓>	Circuit B loader 2 Off	<1> <ENTR> to enable, <0> <ENTR> to stop
	<↓>	Circuit B hot gas bypass Off	<1> <ENTR> to enable, <0> <ENTR> to stop

## History function and subfunctions

HISTORY			
SUBFUNCTION	KEYPAD ENTRY	DISPLAY	COMMENT
1 Operating Hours	<1> <HIST>	Machine Operating Hours xxx.x hours	
	<↓>	Machine Starts xxx	
	<↓>	Circuit A	
	<↓>	Operating hours xxx.x hours	
	<↓>	Compressor A1 Hours xxx.x hours	
	<↓>	Compressor A2 Hours xxx.x hours	
	<↓>	Starts	
	<↓>	Compressor A1 Starts xxx	
	<↓>	Compressor A2 Starts xxx	
	<↓>	Circuit B	
	<↓>	Operating hours xxx.x hours	
	<↓>	Compressor B1 Hours xxx.x hours	
	<↓>	Compressor B2 Hours xxx.x hours	
	<↓>	Starts	
	<↓>	Compressor B1 Starts xxx	
	<↓>	Compressor B2 Starts xxx	
2 Alarm History	<2> <HIST>	PREVIOUS ALARM 1 - description Alarm description time/ day of occurrence	Lists 10 most recent alarms. Use EXPN key when necessary
	<↓>	Previous Alarm 2 - description Alarm description time/ day of occurrence	
	<↓>	Previous Alarm 3 - description Alarm description time/ day of occurrence	
	<↓>	Previous Alarm 4 - description Alarm description time/ day of occurrence	
	<↓>	Previous Alarm 5 - description Alarm description time/ day of occurrence	
	<↓>	Previous Alarm 6 - description Alarm description time/ day of occurrence	
	<↓>	Previous Alarm 7 - description Alarm description time/ day of occurrence	
	<↓>	Previous Alarm 8 - description Alarm description time/ day of occurrence	
	<↓>	Previous Alarm 9 - description Alarm description time/ day of occurrence	
	<↓>	Previous Alarm 10 - description Alarm description time/ day of occurrence	

## Setpoint function

Setpoints are entered through the keypad. Setpoints can be changed within the upper and lower limits, which are fixed. The ranges are listed below.

### Cooling setpoint 1,2

Water: 3.3 to 21.1°C  
 Medium temperature brine: -10 to 21.1°C  
 Low temperature brine: -25 to 21.1°C

### Heating and setpoint 1,2

Water and medium temperature brine: 26.7 to 60°C

### Reset setpoints

Maximum reset range: -17 to 17°C  
 External temperature reset: -40 to 115°C  
 Chiller fluid ΔT: 0 to 8°C  
 External signal reset: 4 to 20 mA

### Demand limit setpoints

Switch input: Step 1 – 0 to 100 % capacity reduction  
 Step 2 – 0 to 100 % capacity reduction  
 External signal: Maximum demand limit: 4 to 20 mA  
 Minimum demand limit: 4 to 20 mA  
 Loadshed demand Delta: 0 to 60 %  
 Maximum loadshed time: 0 to 120 min.

### Head pressure setpoints

Air-cooled chillers: 26.7 to 57.2°C  
 Water-cooled chillers: 26.7 to 53.3°C

SETPOINT (CONT.)			
SUBFUNCTION	KEYPAD ENTRY	DISPLAY	COMMENT
	<↓>	Minutes off time xxx min.	
	<↓>	Motor Temp. setpoint xxx.x °C	
2 Units	<2> <SET>	US IMPERIAL/METRIC 0	0 = English 1 = Metric
3 Address	<3> <SET>	TARGET ADDRESS x	
	<↓>	TARGET BUS NUMBER x	
4 Time	<4> <SET>	Day of week Monday	Mon = 1, Tues = 2 etc.
	<3> <ENTER>	Day of week Wednesday	Day of week set
	<↓>	TIME (HOUR:MIN) 00:00	Enter military format
	<10.30>	TIME (HOUR:MIN) 10:30	Time of day set
	<ENTER>	10:30	
	<↓>	DAY OF MONTH xx	
	<20> <ENTER>	DAY OF MONTH 20	Day of month set
	<↓>	MONTH OF YEAR xx	
	<05> <ENTER>	MONTH OF YEAR 05	Month of year set
	<↓>	YEAR OF CENTURY xx	
	<96> <ENTER>	YEAR OF CENTURY 96	Year of century set
5 Disable	<5> <SET>	Disable CCN control	0 = no, 1 = yes

SETPOINT			
SUBFUNCTION	KEYPAD ENTRY	DISPLAY	COMMENT
1 Setpoint table	<1> <SET>	COOLING	
	<↓>	Cool setpoint 1 xx.x °C	
	<↓>	Cool setpoint 2 xx.x °C	
	<↓>	Cooling ramp loading xx.x °C	
	<↓>	HEATING	
	<↓>	Head setpoint 1 xx.x °C	
	<↓>	Head setpoint 2 xx.x °C	
	<↓>	Heating ramp loading xx.x °C	
	<↓>	HEAD PRESSURE	
	<↓>	Head pressure setpoint A xxx.x °C	
	<↓>	Head pressure setpoint B xxx.x °C	
	<↓>	DEMAND LIMIT	
	<↓>	Demand switch setpoint 1 xxx.x %	
	<↓>	Demand switch setpoint 2 xxx.x %	
	<↓>	LCW delta alarm limit xxx.x °C	

## Head pressure control

### General

The microprocessor controls the condenser fans (30GX) or analogue water valve (30HXC) to maintain the saturated condensing temperature to a configurable setpoint. The fans will be staged (30GX) or water valve controlled (30HXC) based on each circuit's saturated condensing temperature and compressor status. Water-cooled units (30HXC) operating at less than 20°C for entering condenser water require the use of head pressure control.

The chiller must be field configured for the options appearing below:

CONFIGURATION OPTION	DESCRIPTION	HSIO LOCATION	FACTORY CONFIGURATION
Fan staging select	A/C staging method	<1> <SRVC>	Yes
Motormaster select	Applies to A/C only	<2> <SRVC>	Yes. 0 = none Set to 1 to enable (Motormaster only)
Water valve type	Applies to W/C only	<2> <SRVC>	Yes. 0 = none Set to 1 = 4-20 mA 2 = 0-10 V, 3 = 20-4 mA 4 = 10-0 V

### Fan staging settings for A/C units

UNIT MODEL NUMBER	DESCRIPTION	FAN STAGE ON HSIO	FAN STAGING SELECT NUMBER
30GX 080-105	1 <sup>st</sup> stage compressor status 2 <sup>nd</sup> and 3 <sup>rd</sup> stage common control based on highest SCT	FAN-5 FAN-1 and 2	16
30GX 115-135	1 <sup>st</sup> stage compressor status 2 <sup>nd</sup> and 3 <sup>rd</sup> stage common control based on highest SCT	FAN-5 FAN-1 and 2	14
30GX 150-160	1 <sup>st</sup> stage compressor status 2 <sup>nd</sup> and 3 <sup>rd</sup> stage common control based on highest SCT	FAN-5 FAN-1 and 2	16
30GX 175-265	1 <sup>st</sup> stage each circuit, compressor status 2 <sup>nd</sup> and 3 <sup>rd</sup> stage circuit A independent 2 <sup>nd</sup> stage circuit B independent	FAN-5 and 6 FAN-1 and 2 FAN-3	8
30GX 280	1 <sup>st</sup> stage each circuit, compressor status 2 <sup>nd</sup> and 3 <sup>rd</sup> stage circuit A independent 2 <sup>nd</sup> and 3 <sup>rd</sup> stage circuit B independent	FAN-5 and 6 FAN-1 and 2 FAN-3 and 4	4
30GX 295	1 <sup>st</sup> stage each circuit, compressor status 2 <sup>nd</sup> and 3 <sup>rd</sup> stage circuit A independent 2 <sup>nd</sup> and 3 <sup>rd</sup> stage circuit B independent	FAN-5 and 6 FAN-1 and 2 FAN-3 and 4	10
30GX 325-350	1 <sup>st</sup> stage each circuit, compressor status 2 <sup>nd</sup> and 3 <sup>rd</sup> stage circuit A independent 2 <sup>nd</sup> and 3 <sup>rd</sup> stage circuit B independent	FAN-5 and 6 FAN-1 and 2 FAN-3 and 4	6

### Air-cooled units head pressure control

The fans are controlled based on Saturated Condensing Temperature. The first fan stage for each circuit will be turned on whenever the compressor is turned on and SCT greater than 35°C. A fan stage will be added when the Saturated Condensing Temperature (SCT) exceeds the Head Pressure Setpoint. Once a fan stage has been added, the software will temporarily modify the head pressure setpoint by adding 8.3°C for 35 seconds. A fan stage will be removed when the Saturated Condensing Temperature has been less than the Head Pressure Setpoint - 19.4°C for two minutes. The control will use the higher of the

two Saturated Condensing Temperature values for 30GX 080-160 units. For the 30GX 175 to 350 units, each circuit's fan stage is independently controlled based on the circuit Saturated Condensing Temperature.

### 30GX head pressure control flow charts

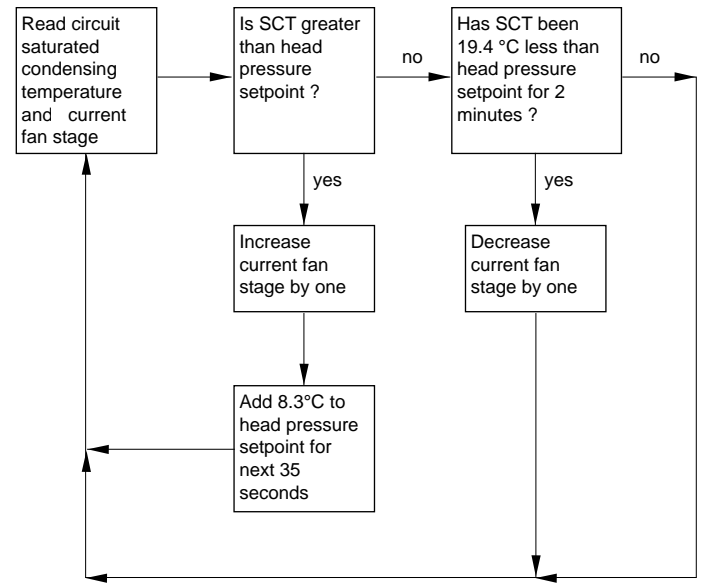

### Water-cooled head pressure control

The 30HXC chillers can be configured to control direct or reverse acting water valves that are controlled by a 4-20 mA signal. A 2-10 VDC signal can be used by installing a 500 ohm resistor across the two output terminals of the 4-20 mA signal. This control scheme reads the Condenser Leaving Water temperature and uses a PID loop to control the head pressure. Proportional, Integral and Derivative gain parameters for water-cooled controls are adjustable and can be found in the Service subfunction. Checkout and adjustment of the PID loop should only be performed by certified Carrier Comfort Network technicians.



## 30GX fan arrangement

30GX 080-090-105

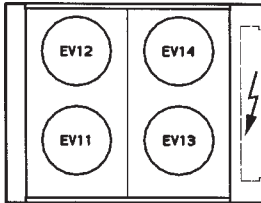

30GX 115-125-135

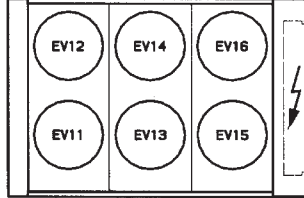

30GX 150-160

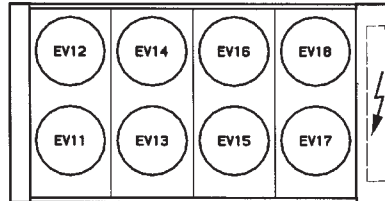

30GX 175-205-225

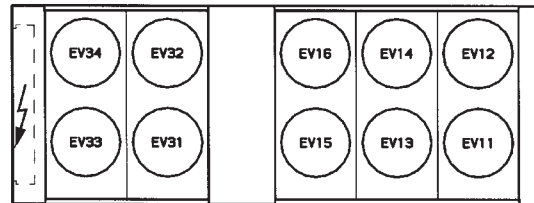

30GX 250-265

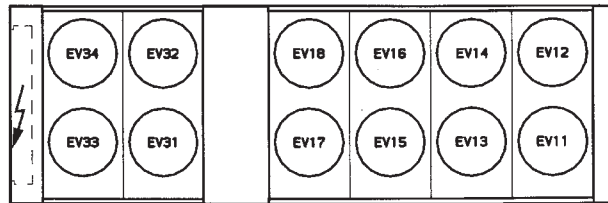

30GX 280

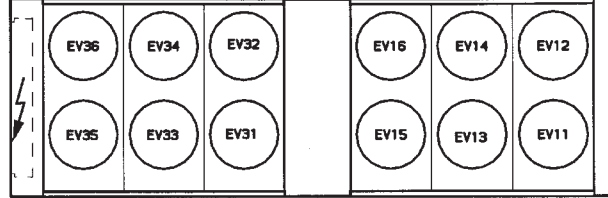

30GX 295

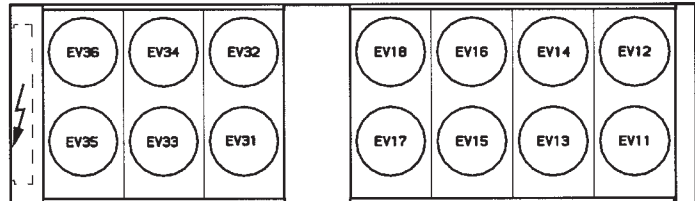

30GX 325-350

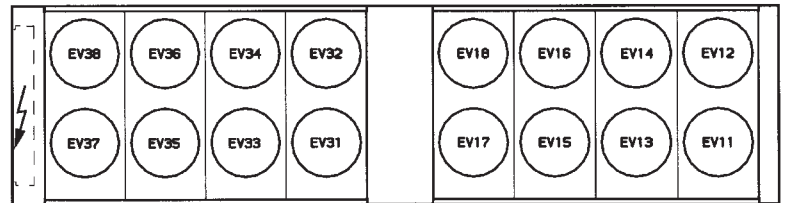

Fan stage on HSIO	Fans controlled on the unit					
	FAN 1	FAN 2	FAN 3	FAN 4	FAN 5	FAN 6
30GX						
080-105	EV 12	EV 13,14	-	-	EV 11	-
115-135	EV 13,14	EV 15,16	-	-	EV 11,12	-
150-160	EV 13,14	EV 15 to 18	-	-	EV 11,12	-
175-225	EV 13,14	EV 15,16	EV 33,34	-	EV 11,12	EV 31,31
250-265	EV 13,14	EV 15,16	EV 33,34	-	EV 11,12	EV 31,32
280	EV 13,14	EV 15,16	EV 33,34	EV 35,36	EV 11,12	EV 31,32
295	EV 13,14	EV 15 to 18	EV 33,34	EV 35,36	EV 11,12	EV 31,32
325-350	EV 13,14	EV 15 to 18	EV 33,34	EV 35 to 38	EV 11,12	EV 31,32

## PRE-START-UP PROCEDURE

Do not attempt to start the chiller until the following checks have been completed.

### System Check

- 1 - Check all auxiliary components such as the chilled fluid circulating pump, air-handling equipment, or other equipment to which the chiller supplies liquid. Consult the manufacturer's instructions. If the unit has field-installed accessories, be sure all are properly installed and wired correctly. Refer to the unit wiring diagrams.
- 2 - Check the cooler flow switch for proper configuration and operation (<8> <STAT> from HSIO II). Ensure the switch closes when the pump is on and opens when the pump is turned off.
- 3 - Open the discharge and liquid valves in each circuit.
- 4 - If suction valve is installed, open the suction service valves in each circuit. Service valve is located below the compressor in the cooler suction connection flange.
- 5 - Open the oil shut off valves located by the oil pre-filter.
- 6 - Check the tightness of all electrical connections.
- 7 - Check to ensure the unit is level per the installation instructions.
- 8 - Check the incoming power supply for proper phasing. This can be done by turning on both the line voltage and control voltage power supplies. Leave the LOCAL/OFF/REMOTE switch in the OFF position. If the incoming power is not phased correctly, the CPM will generate an alarm for voltage phase reversal. Press <1> <STAT> at the HSIO II to check for this alarm. If this alarm is present, shut down power supplies and switch any two incoming power leads at the control box terminal block.

### ATTENTION

**DO NOT make any changes to the factory installed compressor power wiring in the control box or at the compressor junction box. Doing so will cause permanent damage to the compressor and will require compressor replacement.**

- 9 - Check all field configuration data and setpoints.
- 10 - Enter correct date, time and operating schedule(s).
- 11 - Verify operation of solenoids, pumps, valves, compressors, etc. as listed in the Checklist.
- 12 - Check incoming power supply for proper nameplate voltage and for any voltage imbalance as defined below.
- 13 - Open condenser water valves. Check condenser water pump for proper operation.

## START-UP AND OPERATION

### Actual Start-up

Actual start-up should be done only under supervision of a qualified refrigeration mechanic.

- 1 - Set leaving fluid temperature. No cooling range adjustment is necessary.
- 2 - Start chilled fluid pump.
- 3 - Switch LOCAL/OFF/REMOTE switch to LOCAL or REMOTE.
- 4 - Provided there is a load on the chiller, allow the machine to operate and confirm that everything is functioning properly. Verify that the leaving fluid temperature agrees with the cooling setpoint (1 or 2), or if reset is being used, the modified setpoint. Chiller is controlling to the Control Point displayed under <2> <STAT>.

### Operating Sequence

The chiller is started by switching the LOCAL/OFF/REMOTE switch to either LOCAL or REMOTE. On a command for cooling, the oil pump will be turned on to start the pre-lubrication process. After a short period of time, the oil solenoid will be opened and the control will read the oil pressure from the transducer and determine if sufficient pressure has been built up. If there is not sufficient pressure, an alarm will be generated and the compressor will not be started. Upon building pressure, the compressor will be allowed to start. For across the line (XL) start chillers, the compressor will start and come up to full speed within 1-3 seconds. For star delta start chillers, contactors KM1 and KM1-B (starter contactor assembly) will be closed and the compressor will be started in a Wye configuration. This method reduces the locked rotor current requirements by approximately 60%, while maintaining enough torque to bring the compressor up to full speed. After 6-8 seconds, the CPM module will switch out contactor KM1-B and bring in contactor KM1-A which will run the motor in a Delta configuration (same configuration that XL units run).

Once the compressor is successfully running, the control will load the compressor and add additional stages of capacity as needed to satisfy the leaving fluid setpoint. Head pressure can be controlled with a field installed condenser water valve.

## TROUBLESHOOTING

The 30HXC/GX Screw chiller control has many features to aid the technicians in troubleshooting. By using the keypad and display module and the status function, actual operating conditions of the chiller are displayed while the unit is running. The test function allows for operational checkout of compressor loaders, EXV's, solenoids and other components while the chiller is stopped. The Service function displays how configurable items are configured and provides a manual control mode where the compressors can be started and loaded. If an operating fault is detected, an alarm is generated and an alarm code is displayed under the subfunction <1> <STAT> along with an explanation of the fault. Up to 10 current alarm codes are stored under this subfunction.

### Checking display codes

To determine how the machine has been programmed to operate, check the diagnostic information displayed in the Status function and the configuration displayed in the Service function.

### Unit shutoff

To shut the unit off, move the LOCAL/OFF/REMOTE switch to OFF position. All compressors and solenoids stop immediately.

### Complete unit stoppage

Complete unit stoppage can be caused by any of the following conditions:

- 1 - Cooling load satisfied.
- 2 - Remote on/off contacts open.
- 3 - Programmed schedule.
- 4 - Emergency stop command from CCN.
- 5 - General power failure.
- 6 - Blown fuse in control power feed disconnect.
- 7 - Open control circuit fuse(s)
- 8 - LOCAL/OFF/REMOTE switch moved to OFF position.
- 9 - Freeze protection trip.
- 10 - Low flow protection trip.
- 11 - Open contacts in chilled water flow switch.
- 12 - Open contacts in any auxiliary interlock. Terminals that are jumpered from factory are in series with control switch. Opening the circuit between these terminals places unit in stop mode, similar to moving the control switch to OFF position. Unit cannot start if these contacts are open. If they are open while unit is running, the unit stops.
- 13 - Cooler entering or leaving fluid thermistor failure.
- 14 - Low/high transducer supply voltage.
- 15 - Loss of communications between processor module and other control modules.
- 16 - Low refrigerant pressure.
- 17 - Off-to-on delay is in effect.

## Single Circuit Stoppage

Single circuit stoppage can be caused by the following:

- 18 - Low oil pressure.
- 19 - Open contacts in high pressure switch (1330 kPa on 30HXC and 2180 kPa on 30GX)
- 20 - Low refrigerant pressure.
- 21 - Thermistor failure.
- 22 - Transducer failure.
- 23 - Alarm condition from CPM module.
- 24 - Overload relay trip. Stoppage of one circuit by a safety device action does not affect other circuit. When a safety device trips, the circuit is shut down immediately and EXV closes.

### Restart procedure

After the cause for stoppage has been corrected, restart is either automatic or manual, depending on the fault. Manual reset requires that the alarm(s) be reset via the HSIO II. Press <1> <STAT> and then <1> <ENTR> to clear manual reset alarms. If the Alarm Reset Select feature is selected (<3> <SRVC>), a manual reset alarm can also be reset by switching the LOR switch from LOCAL/REMOTE to OFF and back to LOCAL/REMOTE again. If an alarm was from the CPM module, manual reset requires that the alarm(s) be reset via the control circuit breaker QF2. Some typical fault conditions are described below. For a complete list of fault conditions, codes, and reset type, see the Alarm and Alert codes table.

Power failure external to the unit - Unit restarts automatically when power is restored.

### Alarms and alert

These are warnings of abnormal or fault conditions, and may cause either one circuit or the whole unit to shut down. They are assigned code numbers as described below. The alarm descriptions are displayed on the HSIO II when the <1> <STAT> subfunction is entered.

Following is a detailed description of each alarm and alert code error and possible cause. Manual reset is accomplished by entering <1> <STAT> from the HSIO II and pressing <1> <ENTR> or moving the LOCAL/OFF/REMOTE switch to the OFF position, then back to LOCAL or REMOTE position (if Alarm Reset Select is enabled). See Table below for listing of each alarm and alert code.

## Alarms and alerts codes table

Alarm/Alert code	Alarm or Alert	Description	Why was this alarm generated ?	Action taken by control	Reset method	Probable cause
0	–	No alarms or alerts exist		–	–	–
1.xx	Alert	Compressor A1 failure	See CPM subcodes below	See CPM subcodes below	Manual	
2.xx		Compressor A2 failure	See CPM subcodes below	See CPM subcodes below	Manual	
5.xx		Compressor B1 failure	See CPM subcodes below	See CPM subcodes below	Manual	
6.xx		Compressor B2 failure	See CPM subcodes below	See CPM subcodes below	Manual	
CPM Subcodes (xx)	All are alarm codes					
0	–	No error		–	–	–
1		High pressure switch trip	HPS input to CPM module open	Comp. shut down	Manual	Loss of condenser water flow. Operation beyond chiller capability. Liquid valve not open.
2		No motor current	CPM module reads less than 10 % of MTA on all legs for > 3 seconds	Comp. shut down	Manual	Power supply disconnected, blown fuse(s), wiring error, contactor not energized, faulty current toroid.
25		Current imbalance > 10 % (Alarm)	CPM measures current balance between phases greater than 10 %	Circuit shut down	Manual	Loose terminals on power wires. Poor power supply. Displayed only if alarm feature is enabled in <3> <SRVC>
27		Current imbalance > 10 % (Warning)	CPM measures current balance between phases greater than 10 %	None		Loose terminals on power wires. Poor power supply. Displayed only if alarm feature is disabled in <3> <SRVC>
3		Current imbalance > 18 % (Alarm)	CPM measures current balance between phases greater than 18 % for 25 minutes	Circuit shut down	Manual	Loose terminals on power wires. Poor power supply.
35		Single phase current loss	CPM measures current balance between phases greater than 20 %	Circuit shut down	Manual	Blown fuse, wiring error.
4		High motor current	CPM detects high current compared to MTA setting	Comp. shut down	Manual	Operation beyond chiller capability, improperly punched configuration header, blown fuse.
5		Ground fault	CPM detects ground current (2.5 ± 2.0 amps)	Comp. shut down	Manual	Motor winding(s) gone to ground, wiring error.
55		Voltage imbalance > 3 % (Alarm)	CPM measures voltage balance between phases greater than 3 %	Circuit shut down	Manual	Compressor fault, local utility. supply imbalance. Poor power supply. Displayed only if alarm feature is enabled in <3> <SRVC>
57		Voltage imbalance > 3 % (Warning)	CPM measures voltage balance between phases greater than 3 %	None		Compressor fault, local utility. supply imbalance. Poor power supply. Displayed only if alarm feature is disabled in <3> <SRVC>
6		Voltage imbalance > 7 %	CPM measures voltage balance between phases greater than 7 % for 25 minutes	Circuit shut down	Manual	Compressor fault, local utility. supply imbalance.
65		Single phase Volts loss	CPM measures current balance between phases greater than 20 %	Circuit shut down	Manual	Blown fuse, wiring error.
7		Volt phase reversal	CPM detects incoming power supply out of phase		Manual	Supply power not in phase. Interchange any two incoming leads.
75		Contactors failure	CPM detects min. 10 % of MTA for 10 seconds after shutting off compressor contactor. Oil solenoid is energized.	Chiller shut down	Manual	Faulty contactor, contactor welded, wiring error.
8		Current phase reversal	CPM detects phase reversal from toroid reading	Circuit shut down	Manual	Multiple terminal block power supply leads not in phase. Interchange any two leads at ONE of the terminal blocks.
85		Motor over temperature	CPM detects high motor temperature	Comp. shut down	Manual	Solenoid failure, low refrigerant charge.
9		Open thermistor	CPM detects open circuit in motor temp. thermistor	Comp. shut down	Manual	Wiring error or faulty thermistor*
95		Config header fault	CPM finds error with MTA value punched out in header	Comp. shut down	Manual	Header on CPM board improperly punched out, header not fully seated in CPM board.
10		Shorted thermistor	CPM detects short circuit in motor temp. thermistor	Comp. shut down	Manual	Wiring error or faulty thermistor*
7	Alert	Cir. A discharge gas Thermistor failure	Thermistor outside range of of -40 to 118°C or DGT > 98.9°C	Circuit A shut down	Manual	Thermistor failure, motor cooling solenoid failure or wiring error.
8	Alert	Cir. B discharge gas Thermistor failure	Thermistor outside range of of -10 to 118°C or DGT > 98.9°C	Circuit B shut down	Manual	Thermistor failure, motor cooling solenoid failure or wiring error.
9	Alarm	Cooler leaving fluid Thermistor failure	Thermistor outside range of of -40 to 118°C	Chiller shut down Uses 0.1°F/% total capacity as rise/ton.	Automatic	Thermistor failure, damaged cable/wire or wiring error.
10	Alarm	Cooler entering fluid Thermistor failure	Thermistor outside range of of -40 to 118°C	Chiller shut down Uses 0.1°F/% total capacity as rise/ton.	Automatic	Thermistor failure, damaged cable/wire or wiring error.

## Alarms and alerts codes table (cont.)

Alarm/Alert code	Alarm or Alert	Description	Why was this alarm generated ?	Action taken by control	Reset method	Probable cause
11	Alert	Condenser leaving fluid Thermistor failure	Thermistor outside range of -40 to 118°C	None. Chiller continues to run	Automatic	Thermistor failure, damaged cable/wire or wiring error.
12	Alert	Condenser entering fluid Thermistor failure	Thermistor outside range of -40 to 118°C	None. Chiller continues to run	Automatic	Thermistor failure, damaged cable/wire or wiring error.
15	Alert	Compressor A1 high motor temperature	Thermistor outside range of -39.9 to 118°C for five consecutive readings.	Compressor A1 shut down	Manual	Thermistor failure, faulty motor cooling solenoid.
16	Alert	Compressor A2 high motor temperature	Thermistor outside range of -39.9 to 118°C for five consecutive readings.	Compressor A2 shut down	Manual	Thermistor failure, faulty motor cooling solenoid.
17	Alert	Compressor B1 high motor temperature	Thermistor outside range of -39.9 to 118°C for five consecutive readings.	Compressor B1 shut down	Manual	Thermistor failure, faulty motor cooling solenoid.
18	Alert	Compressor B2 high motor temperature	Thermistor outside range of -39.9 to 118°C for five consecutive readings.	Compressor B2 shut down	Manual	Thermistor failure, faulty motor cooling solenoid.
19	Alert	Circuit A low oil temp. at start-up	DGT/oil temp. less than SCT + oil rise	Air-cooled chillers not allowed to start	Automatic	Failed oil heater
20	Alert	Circuit B low oil temp. at start-up	DGT/oil temp. less than SCT + oil rise	Air-cooled chillers not allowed to start	Automatic	Failed oil heater
21	Alert	External reset temperature thermistor failure	Thermistor outside range of -40 to 118°C	Reset disabled. Runs under normal control/setpoints	Automatic	Thermistor failure or wiring error
22	Alert	Circuit A discharge pressure transducer failure	Calibration offset more than 41 kPa or voltage ratio (volts read/ref. voltage) more than 99.9 % or less than 0.5 %.	Circuit A shut down	Automatic	Transducer failure, power supply failure or wiring damage/error.
23	Alert	Circuit B discharge pressure transducer failure	Calibration offset more than 41 kPa or voltage ratio (volts read/ref. voltage) more than 99.9 % or less than 0.5 %.	Circuit B shut down	Automatic	Transducer failure, power supply failure or wiring damage/error.
24	Alert	Circuit A suction pressure transducer failure	Calibration offset more than 41 kPa or voltage ratio (volts read/ref. voltage) more than 99.9 % or less than 0.5 %.	Circuit A shut down	Automatic	Transducer failure, power supply failure or wiring damage/error.
25	Alert	Circuit B suction pressure transducer failure	Calibration offset more than 41 kPa or voltage ratio (volts read/ref. voltage) more than 99.9 % or less than 0.5 %.	Circuit B shut down	Automatic	Transducer failure, power supply failure or wiring damage/error.
26	Alert	Comp. A1 oil pressure transducer failure	Calibration offset more than 41 kPa or voltage ratio (volts read/ref. voltage) more than 99.9 % or less than 0.5 %.	Comp. A1 shut down	Automatic	Transducer failure, power supply failure or wiring damage/error.
27	Alert	Comp. A2 oil pressure transducer failure	Calibration offset more than 41 kPa or voltage ratio (volts read/ref. voltage) more than 99.9 % or less than 0.5 %.	Comp. A2 shut down	Automatic	Transducer failure, power supply failure or wiring damage/error.
28	Alert	Comp. B1 oil pressure transducer failure	Calibration offset more than 41 kPa or voltage ratio (volts read/ref. voltage) more than 99.9 % or less than 0.5 %.	Comp. B1 shut down	Automatic	Transducer failure, power supply failure or wiring damage/error.
29	Alert	Comp. B2 oil pressure transducer failure	Calibration offset more than 41 kPa or voltage ratio (volts read/ref. voltage) more than 99.9 % or less than 0.5 %.	Comp. B2 shut down	Automatic	Transducer failure, power supply failure or wiring damage/error.
30	Alert	Circuit A economizer transducer failure	Calibration offset more than 41 kPa or voltage ratio (volts read/ref. voltage) more than 99.9 % or less than 0.5 %.	Circuit A shut down	Automatic	Transducer failure, power supply failure or wiring damage/error.
31	Alert	Circuit B economizer transducer failure	Calibration offset more than 41 kPa or voltage ratio (volts read/ref. voltage) more than 99.9 % or less than 0.5 %.	Circuit B shut down	Automatic	Transducer failure, power supply failure or wiring damage/error.
32	Alarm	Transducer supply outside 4.5 to 5.5 Volts	Reference voltage measured at PSIO-1, less than 4.5 V or greater than 5.5 V.	Chiller shut down	Automatic	Power supply failure or wiring error. Low transformer voltage.
34	Alert	4-20 mA reset input out of range	If configured and input signal less than 2 mA or greater than 20 mA.	Reset function disabled. Normal setpoint used.	Automatic	Faulty signal generator, wiring error.
35	Alert	4-20 mA demand limit input out of range	If configured and input signal less than 2 mA or greater than 20 mA.	Demand limit ignored. Runs under normal control base on 100 % demand limit	Automatic	Faulty signal generator, wiring error.
36	Alarm	Loss of communication with "Hardware point"	PSIO has lost communication with one of the points in Table 18.		Automatic	Failed module, wiring error, failed transformer, loose connection plug, wrong address.
37	Alert	Circuit A low saturated suction temperature	SST reads 3.3°C or more below the freeze point for 3 minutes. Point is 1.1°C for water, setpoint minus 4.4°C for brines.	Circuit A shut down	Manual	Low refrigerant charge, plugged strainer, faulty expansion valve. Low water flow.
38	Alert	Circuit B low saturated suction temperature	SST reads 3.3°C or more below the freeze point for 3 minutes. Point is 1.1°C for water, setpoint minus 4.4°C for brines.	Circuit B shut down	Manual	Low refrigerant charge, plugged strainer, faulty expansion valve. Low water flow.

## Alarms and alerts codes table (cont.)

Alarm/Alert code	Alarm or Alert	Description	Why was this alarm generated ?	Action taken by control	Reset method	Probable cause
40	Alert	Compressor A1 low oil pressure	Oil pressure differential below oil Setpoint 1 or 2 (see low oil pressure Alert Criteria and Setpoints)	Comp. A1 shut down	Manual	Low water temperature, plugged oil filter, closed oil valve, bad oil solenoid, compressor oil check valve stuck, plugged oil strainer
41	Alert	Compressor A2 low oil pressure	Oil pressure differential below oil Setpoint 1 or 2 (see low oil pressure Alert Criteria and Setpoints)	Comp. A2 shut down	Manual	Low water temperature, plugged oil filter, closed oil valve, bad oil solenoid, compressor oil check valve stuck, plugged oil strainer
42	Alert	Compressor B1 low oil pressure	Oil pressure differential below oil Setpoint 1 or 2 (see low oil pressure Alert Criteria and Setpoints)	Comp. B1 shut down	Manual	Low water temperature, plugged oil filter, closed oil valve, bad oil solenoid, compressor oil check valve stuck, plugged oil strainer
43	Alert	Compressor B2 low oil pressure	Oil pressure differential below oil Setpoint 1 or 2 (see low oil pressure Alert Criteria and Setpoints)	Comp. B2 shut down	Manual	Low water temperature, plugged oil filter, closed oil valve, bad oil solenoid, compressor oil check valve stuck, plugged oil strainer
44	Alarm	Circuit A condenser freeze protection	For W/C chillers only, if SCT < 1.1°C	Chiller shut down. Turn cond. pump on if chiller is off	Automatic	Failed/bad discharge pressure transducer, refrigerant leak
45	Alarm	Circuit B condenser freeze protection	For W/C chillers only, if SCT < 1.1°C	Chiller shut down. Turn cond. pump on if chiller is off	Automatic	Failed/bad discharge pressure transducer, refrigerant leak
46	Alarm	Cooler freeze protection	Cooler EWT or LWT less than freeze point. Freeze point is 1.1°C for water, cooling setpoint minus 4.4°C for brines	Chiller shut down. Leave cond. pump on. Turn cond. pump on if chiller is off.	Automatic	Faulty thermistor, low water flow.
47	Alert	Circuit A high saturated suction temperature	After first 90 seconds SST > 12.8°C and EXV < 1 %.	Circuit A shut down.	Manual	Faulty expansion valve, liquid level sensor or transducer
48	Alert	Circuit B high saturated suction temperature	After first 90 seconds SST > 12.8°C and EXV < 1 %.	Circuit B shut down.	Manual	Faulty expansion valve, liquid level sensor or transducer
49	Alarm	Loss of condenser flow	Flow switch not closed within 1 minute after pump is started	Chiller shut down.	Manual	Low condenser water flow condenser pump.
50	Alarm	Illegal configuration x	Illegal configuration has been entered. Correction needed	Chiller cannot start.	Manual	Configuration error.
51	Alarm	Initial configuration required	No configuration has been entered.	Chiller cannot start.	Manual	Configuration omitted.
52	Alarm	Unit is in emergency stop	CCN command received to shut unit down.	Chiller shut down.	CCN/Automatic	Network command.
53	Alarm	Cooler pump interlock failed at start-up	Interlock did not close within 1 minute after transition	Chiller shut down. Pump turned off.	Automatic	Failure of cooler pump or controls.
54	Alarm	Cooler pump interlock opened unexpectedly	Interlock opened for at least 5 seconds during operation	Chiller shut down. Pump turned off.	Automatic	Failure of cooler pump or controls.
55	Alarm	Cooler pump interlock closed when pump off	Interlock closed when pump relay is off	Cooler pump remains off. Unit prevented from starting.	Manual	Failure of cooler pump relay or interlock, welded contacts.
56	Alert	Loss of communication with WSM	No communications have been received by PSIO within 5 minutes of last transmission.	WSM forces removed. Runs under own control.	Automatic	Failed module, wiring error, failed transformer, loose connection plug, wrong address.
57	Alert	Circuit A liquid level sensor failure	Sensor reads 118°C or -40°C with SST > -12.8°C.	Runs, but controls EXV based on discharge superheat	Automatic	Thermistor circuit open, faulty liquid level sensor, wiring error.
58	Alert	Circuit B liquid level sensor failure	Sensor reads 118°C or -40°C with SST > -12.8°C.	Runs, but controls EXV based on discharge superheat	Automatic	Thermistor circuit open, faulty liquid level sensor, wiring error.
59	Alarm	Compressor A1 Prestart oil pressure	Oil pump did not build sufficient pressure during pre-lube cycle.	Circuit cannot start.	Manual	Low oil, oil pump failure, oil solenoid failure, oil transducer failure.
60	Alarm	Compressor A2 Prestart oil pressure	Oil pump did not build sufficient pressure during pre-lube cycle.	Circuit cannot start.	Manual	Low oil, oil pump failure, oil solenoid failure, oil transducer failure.
61	Alarm	Compressor B1 Prestart oil pressure	Oil pump did not build sufficient pressure during pre-lube cycle.	Circuit cannot start.	Manual	Low oil, oil pump failure, oil solenoid failure, oil transducer failure.
62	Alarm	Compressor B2 Prestart oil pressure	Oil pump did not build sufficient pressure during pre-lube cycle.	Circuit cannot start.	Manual	Low oil, oil pump failure, oil solenoid failure, oil transducer failure.
63	Alarm	Circuits A&B off for alerts Unit down	Control has shut down both circuits due to alerts.	None.	Automatic	Check individual alarms.
64	Alert	Circuit A loss of charge	Discharge pressure reading < 69 kPa for 30 seconds	Circuit A shut down.	Manual	Refrigerant leak or transducer failure.
65	Alert	Circuit B loss of charge	Discharge pressure reading < 69 kPa for 30 seconds	Circuit B shut down.	Manual	Refrigerant leak or transducer failure.
66	Alarm	Loss of communication with FSM	No communications have been received by PSIO within 5 minutes of last transmission.	FSM forces removed. Runs under own control.	Automatic	Wiring faulty or module failure.

## Alarms and alerts codes table (cont.)

Alarm/Alert code	Alarm or Alert	Description	Why was this alarm generated ?	Action taken by control	Reset method	Probable cause
67	Alert	Circuit A high discharge pressure	SCT > MCT_SP + 2.8°C	Circuit A shut down	Automatic	Faulty transducer/high pressure switch, restricted condenser water flow.
68	Alert	Circuit B high discharge pressure	SCT > MCT_SP + 2.8°C	Circuit B shut down	Automatic	Faulty transducer/high pressure switch, restricted condenser water flow.
70	Alert	High leaving chilled water temperature	LCW read > LCW Delta alarm limit and total capacity is 100 % and current LCW > LCW reading 1 minute ago.	Alert only. None	Automatic	Building load greater than capacity, low water/brine flow, or compressor fault. Check for other alarms or alerts.
71	Alert	Circuit A low oil level/flow	Level switch input open.	Circuit A shut down	Manual	Low oil level, failed switch, wiring error.
72	Alert	Circuit B low oil level/flow	Level switch input open.	Circuit B shut down	Manual	Low oil level, failed switch, wiring error.
73	Alert	Circuit A low discharge superheat	Superheat < 2.8°C for 10 minutes	Circuit A shut down	Manual	Faulty thermistor, transducer or EXV.
74	Alert	Circuit B low discharge superheat	Superheat < 2.8°C for 10 minutes	Circuit B shut down	Manual	Faulty thermistor, transducer or EXV.
75	Alarm	Compressor A1 max. oil Delta P, check oil line	(Discharge pressure - oil pressure) > 680 kPa for more than 5 seconds	Comp. A1 shut down	Manual	Low water temperature, plugged oil filter, closed oil valve, bad oil solenoid, compressor oil check valve stuck, plugged oil strainer
76	Alarm	Compressor A2 max. oil Delta P, check oil line	(Discharge pressure - oil pressure) > 680 kPa for more than 5 seconds	Comp. A2 shut down	Manual	Low water temperature, plugged oil filter, closed oil valve, bad oil solenoid, compressor oil check valve stuck, plugged oil strainer
77	Alarm	Compressor B1 max. oil Delta P, check oil line	(Discharge pressure - oil pressure) > 680 kPa for more than 5 seconds	Comp. B1 shut down	Manual	Low water temperature, plugged oil filter, closed oil valve, bad oil solenoid, compressor oil check valve stuck, plugged oil strainer
78	Alarm	Compressor B2 max. oil Delta P, check oil line	(Discharge pressure - oil pressure) > 680 kPa for more than 5 seconds	Comp. B2 shut down	Manual	Low water temperature, plugged oil filter, closed oil valve, bad oil solenoid, compressor oil check valve stuck, plugged oil strainer
79	Alarm	Compressor A1 failed oil solenoid	Diff. oil pressure > 17 kPa during period after oil pump starts and before oil solenoid opens	Comp. A1 not allowed to start	Manual	Faulty oil solenoid valve.
80	Alarm	Compressor A2 failed oil solenoid	Diff. oil pressure > 17 kPa during period after oil pump starts and before oil solenoid opens	Comp. A2 not allowed to start	Manual	Faulty oil solenoid valve.
81	Alarm	Compressor B1 failed oil solenoid	Diff. oil pressure > 17 kPa during period after oil pump starts and before oil solenoid opens	Comp. B1 not allowed to start	Manual	Faulty oil solenoid valve.
82	Alarm	Compressor B2 failed oil solenoid	Diff. oil pressure > 17 kPa during period after oil pump starts and before oil solenoid opens	Comp. B2 not allowed to start	Manual	Faulty oil solenoid valve.

### Legend:

CPM: Compressor Protection Module

FSM: Flotronic™ System Manager

PS: Power supply

WSM: Water System Manager

MTA: Compressor Must Trip Amps.

**Low oil pressure alert criteria and setpoints  
(Alert 40 to 43)**

Two oil pressure setpoints are used. Oil setpoint 1 and oil setpoint 2.  
Oil setpoint 1 (oil pressure differential  $P_o - P_e$ ) is calculated as follows:

**30HXC**

- Oil setpoint 1 = 70 kPa if saturated suction pressure  $\leq$  240 kPa
- Oil setpoint 1 = 86 kPa if saturated suction pressure  $>$  240 kPa but  $<$  450 kPa
- Oil setpoint 1 = 100 kPa if saturated suction pressure  $>$  450 kPa.

**30GX**

Oil setpoint 1 = 70 kPa for all saturated suction pressure  
Oil setpoint 2 (oil pressure differential  $P_o - P_s$ ) changes as a function of the operating conditions (compressor pressure differential).  
The curve below gives the minimum oil pressure differential corresponding to oil setpoint 2.

The two setpoints are used by the control for the low oil pressure alert trip criteria below:

1. Oil Pressure is ignored during the first five seconds after a compressor is started.
2. In period between 5 and 30 seconds after starting, the alert will be generated if  $(P_o - P_e) < [(Oil\ Setpoint\ 1)/30] * (Compressor\ run\ time\ in\ seconds)$  for 3 consecutive readings.
3. After 30 seconds run time, the alert will be generated if:
  - a.  $(P_o - P_e) <$  oil setpoint 1 for 15 seconds OR
  - b.  $(P_o - P_s) <$  oil setpoint 2 for 15 seconds

Where  $P_d$  = Discharge pressure,  $P_s$  = Suction pressure,  $P_o$  = Oil pressure and  $P_e$  = Economizer pressure

**NOTE**

*( $P_o - P_e$ ) is the Oil pressure differential displayed in <3> <STAT> for Circuit A and <5> <STAT> for circuit B.*

**Minimum oil pressure vs compressor pressure differential**

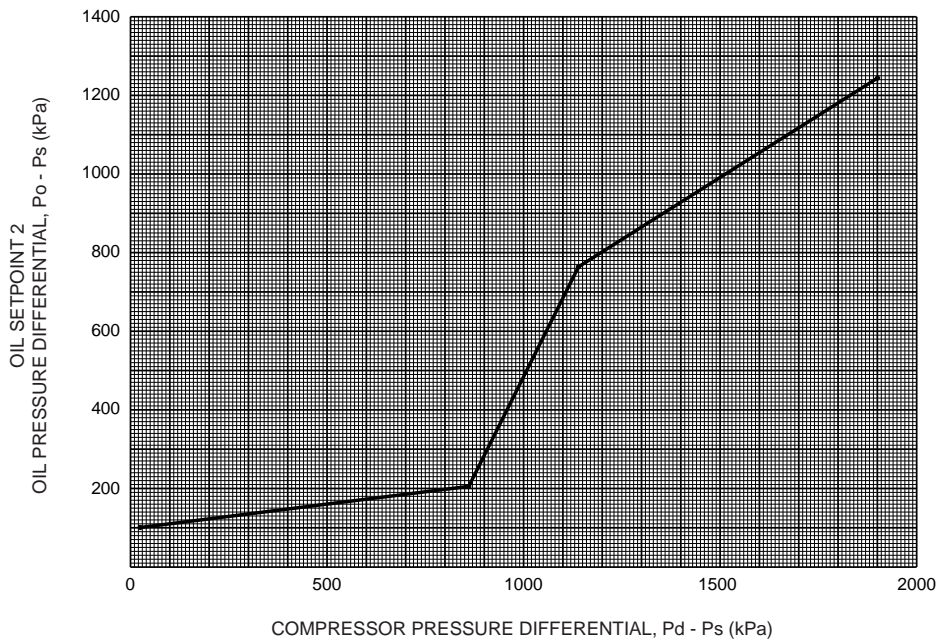



## MAINTENANCE

### Refrigerant Charging - Adding Charge

#### **IMPORTANT**

*These units are designed for use with R-134a only. DO NOT USE ANY OTHER refrigerant in these units.*

#### **CAUTION**

*When adding or removing charge, circulate water through the condenser (HX) and cooler at all times to prevent freezing. Freezing damage is considered abuse and may void the Carrier warranty.*

#### **CAUTION**

*DO NOT OVERCHARGE system. Overcharging results in higher discharge pressure with higher cooling fluid consumption, possible compressor damage and higher power consumption.*

### Indication of low charge on a 30HXC system

#### **NOTE**

*To check for low refrigerant charge on a 30HXC, several factors must be considered. A flashing liquid-line sightglass is not necessarily an indication of inadequate charge. There are many system conditions where a flashing sightglass occurs under normal operation. The 30HXC metering device is designed to work properly under these conditions.*

1. Make sure that the circuit is running at a full-load condition. To check whether circuit A is fully loaded, enter <3> <STAT> on the HSIO keypad. The display will read "CIRCUIT A ANALOGUE VALUES". Using the down arrow key on the keypad, scroll down once to "Total Capacity". If this value is 100 %, the circuit is at full-load. To check circuit B, follow the same procedure, but enter <5> <STAT> on the keypad.
2. It may be necessary to use the Manual Control feature to force the circuit into a full-load condition. If this is the case, see the instructions for using the Manual Control feature (Keypad Directory) <8> <SRVC>.
3. With the circuit running at full-load, verify that the cooler leaving fluid temperature is in the range of 5.6 - 7.8 °C.
4. At this condition, observe the refrigerant in the liquid line sightglass. If there is a clear sightglass, and no signs of flashing, then the circuit is adequately charged. Skip the remaining steps.
5. If the refrigerant appears to be flashing, the circuit is probably low on charge. Verify this by checking the EXV Percent Open. This information can be accessed by entering <3> <STAT> on the HSIO keypad for circuit A, or <5> <STAT> for circuit B. Scroll down using the down arrow key on the keypad, until EXV Percent Open is displayed.
6. If the EXV Percent Open is greater than 60 %, and the liquid-line sightglass is flashing, then the circuit is low on charge. Follow the procedure for adding charge.

### To add charge to the 30HXC systems

1. Make sure that the unit is running at full-load, and that the cooler leaving fluid temperature is in the range of 5.6 - 7.8 °C.
2. At these operating conditions, check the liquid-line sightglass. If there is a clear sightglass, then the unit has sufficient charge. If the sightglass is flashing, then check the EXV Percent Open. If this is greater than 60 %, then begin adding charge.

#### **NOTE**

*A flashing liquid-line sightglass at operating conditions other than those mentioned above is not necessarily an indication of low refrigerant charge.*

3. Add 2.5 kg of liquid charge into the cooler using the charging valve located on the top of the cooler.
4. Observe the EXV Percent Open value. The EXV should begin closing as charge is being added. Allow the unit to stabilize. If the EXV Percent Open remains above 60 %, and the sightglass continues flashing, add an additional 2.5 kg of liquid charge.
5. Allow the unit to stabilize, and again check the EXV Percent Open. Continue adding 2.5 kg of liquid refrigerant charge at a time, and allow the unit to stabilize before checking the EXV position.
6. When the EXV Percent Open is in the range of 40 - 60 %, check the liquid line sightglass. Slowly add enough additional liquid charge to ensure a clear sightglass. This should be done slowly to avoid overcharging the unit.
7. Verify adequate charge by continuing to run at full-load with 5.6 - 7.8 °C cooler leaving fluid temperature. Check that the refrigerant is not flashing in the liquid-line sightglass. The EXV Percent Open should be between 40 and 60 %. The cooler level indicator should be in the range of 1.5 - 2.5.

### Indication of low charge on 30GX systems

1. Make sure that the circuit is running at a full-load condition and all condenser fans are energized and running at full speed. To check whether circuit A is fully-loaded, enter <3> <STAT> on the HSIO keypad. The display will read "CIRCUIT A ANALOGUE VALUES". Using the down arrow key on the keypad, scroll down once to "Total Capacity". If this value is 100 %, the circuit is at full-load. To check circuit B, follow the same procedure, but enter <5> <STAT> on the keypad.
2. It may be necessary to use the Manual Control feature to force the circuit into a full-load condition. If this is the case, see the instructions for using the Manual Control feature (Keypad Directory) <8> <SRVC>.
3. With the circuit running at full-load, verify that the cooler leaving fluid temperature is in the range of 5.6 - 7.8 °C.
4. Measure the air temperature entering the condenser coils. Measure the liquid temperature after the tee where the two coil liquid lines join. The liquid temperature should be 8.3°C above the air temperature entering the coils. If the difference is more than this and the sightglass is flashing, the circuit is uncharged. Proceed to step 5.

5. Add 2.5 kg of liquid charge into the cooler using charging valve located in the top of the cooler.
6. Allow the system to stabilize and then recheck the liquid temperature. Repeat step 5 as needed allowing the system to stabilize between each charge addition. Slowly add charge as the sightglass begins to clear to avoid overcharging.

## Oil Charging - Low oil recharging

### Addition of oil charge to 30HX/GX systems

1. If the 30HXC/GX unit shuts-off repeatedly on Low oil Level (alarm number 71 or 72), this may be an indication of inadequate oil charge. It could also mean simply that oil is in the process of being reclaimed from the low-side of the system.
2. Begin by running the unit at full-load for an hour and a half. It is recommended to use the Manual Control feature of the software if the unit does not normally run at full load.
3. After running for 1-1/2 hours allow the unit to re-start and run normally. If the Low Oil Level alarms persist, continue following this procedure.
4. Stop the unit, and jumper the oil level safety switch. This is done by placing a jumper wire between channel 14 (J9) for circuit A, or channel 15 (J9) for circuit B on the basic board.
5. Close the liquid-line service valve, and place a pressure gauge on top of the cooler. Enable the manual control feature using the HSIO keypad, and turn the LOR switch to local. Start the desired compressor by pressing <1> <ENTER> on the keypad, at the appropriate line on the display.
6. Before starting the compressor, the unit will go through its normal pre-lube pump routine. If there is an insufficient level of oil in the oil separator, the compressor will not start, and a Pre-start oil pressure alarm will be posted. Skip to step number 9.
7. If the compressor starts successfully, keep an eye on the cooler pressure gauge. When this gauge reads approximately 70 kPa, press <0> <ENTER> on the HSIO keypad, and move the LOR switch to the off position.
8. Open the liquid-line service valve and allow the unit to re-start and run normally: if the Low Oil Level alarms persist, continue following this procedure.
9. If none of the previous steps were successful, the unit is low on oil charge. Add oil to the oil separator using the oil charging valve on the top of the condenser (30HXC) or on the top of the oil separator (30GX).

### CAUTION

**Do NOT add oil at any other location as improper unit operation may result.**

10. Make sure that the unit is not running when adding oil, as this will make the oil charging process easier. Because the system is under pressure even when the unit is not running, it will be necessary to use a suitable pump (hand or electric pump) to add oil to the system.

11. Using a suitable pump, add 2 liters of Polyolester oil to the system (CARRIER SPEC: PP47-32). Make sure that the oil level safety switch is NOT jumpered, and allow the unit to re-start and run normally.
12. If low oil level problems persist, add another 2 liters of oil. Continue adding oil in 2 l increments until the problem is resolved. If it is necessary to add more than 6 liters of oil to the system, then contact your Carrier distributor service department.

### Integral oil filter change

An integral oil filter in the 06N screw compressor is specified to provide a high level of filtration (3  $\mu$ ) required for long bearing life. As system cleanliness is critical to reliable system operation, there is also a prefilter (12  $\mu$ ) in the oil line just before entering the integral compressor filter.

The replacement integral oil filter element part number is:

Carlyle part number:	8TB0320
Parker part number:	932777Q

An alternate filter element is:

Carrier part number:	KH39MG001
Parker part number:	931984

### Filter Change-Out schedule

The filter should be checked after the first 1000 hours of operation, and every subsequent 4000 hours. The filter should be replaced at any time when the pressure differential across the filter exceeds 2.1 bar.

The pressure drop across the filter can be determined by measuring the pressure at the filter service port and the oil pressure port. The difference in these two pressures will be the pressure drop across the filter, check valve, and solenoid valve. The pressure drop across the check valve and solenoid valve is approximately 0.4 bar, which should be subtracted from the two oil pressure measurements to give the oil filter pressure drop. The oil filter pressure drop should be checked after any occasion that the compressor is shut down on a low oil pressure safety.

### Filter Change-Out Procedure

The following steps outline the proper method of changing the integral oil filter.

1. Shutdown and lockout the compressor.
2. Close the oil filter service valve. Bleed pressure from the filter cavity through the filter service port.
3. Remove the oil filter plug. Remove the old oil filter.
4. Prior to installing the new oil filter, "wet" the o-ring with oil. Install the filter and replace the plug.  
Before closing up the lube oil system, take the opportunity to replace the prefilter, as well.
5. When complete, evacuate the filter cavity through the filter service port. Open the filter service valve. Remove any compressor lockout devices, the compressor is ready to return to operation.

The replacement pre-filter element part number is:  
Carrier part number: XW12EA015

## Service replacement compressor

### Compressor rotation control

Correct compressor rotation is one of the most critical application considerations. Reverse rotation, even for a very short duration, can seriously affect the reliability of the compressor.

The reverse rotation protection scheme must be capable of determining the direction of rotation and stopping the compressor within 300 milliseconds.

Reverse rotation is most likely to occur whenever the wiring to the compressor terminals is disturbed.

To minimize the opportunity for reverse rotation, the following procedure must be applied. Rewire the power cables to the compressor terminal pin as originally wired.

For service replacement compressor, a low pressure switch is included with the compressor. This low pressure switch should be temporarily installed as a hard safety on the high pressure part of the compressor. The purpose of this switch is to protect the compressor against any wiring errors at the compressor terminal pin. The electrical contact of the switch would be wired in series with the high pressure switch. The switch will remain in place until the compressor has been started and direction of rotation has been verified; at this point, the switch will be removed and discarded.

The switch that has been selected for detecting reverse rotation is Carrier part number HK01CB001. This switch opens the contacts when the pressure falls below 50 mm of vacuum. The switch is a manual reset type that can be reset after the pressure has once again risen above 70 kPa. It is critical that the switch be a manual reset type to preclude the compressor from short cycling in the reverse direction.

## EXV Troubleshooting Procedure

### Follow steps below to diagnose and correct EXV/Economizer problems.

On 30HXC/GX units with economizers, verify that the valve for the bubbler tube (bottom of Economizer) is open. Check EXV motor operation first. Press <4> <TEST> on the HSIO keypad and select the appropriate EXV. Press <1> <ENTER> to move the valve to 25 %. You should be able to feel the actuator moving by placing your hand on the EXV or economizer body (the actuator is located about one-half to two-thirds of the way up from the bottom of the economizer shell). Repeat pressing <1> <ENTER> three more times until the display reads 100 % for a target percent (waiting until actuator stops each time). You should feel a hard knocking come from the actuator when it reaches the top of its stroke (can be heard if surroundings are relatively quiet). Press <1> <ENTER> again if necessary to confirm this. Press <0> <ENTER> four times to step the actuator closed in 25 % increments, waiting again in between each move. The actuator should knock when it reaches the bottom of its stroke. If it is believed that the valve is not working properly, contact your Carrier service department for further checks on:

- output signals on EXV module
- wire connections (continuity and tight connection at all pin terminals)
- resistance of the EXV motor windings.

**START-UP CHECKLIST FOR 30HXC/GX LIQUID CHILLERS (USE FOR JOB FILE)**

**Preliminary information**

Job name: .....  
Location: .....  
Installing contractor: .....  
Distributor: .....  
Start-up performed by: .....

**Equipment**

Model: ..... S/N .....

**Compressors**

Circuit A

1. Model # .....  
S/N .....  
Mtr # .....

Circuit B

1. Model # .....  
S/N .....  
Mtr # .....

2. Model # .....  
S/N .....  
Mtr # .....

2. Model # .....  
S/N .....  
Mtr # .....

**Cooler**

Model # ..... Manufactured by .....  
S/N ..... Date .....

**Condenser (30HXC)**

Model # ..... Manufactured by .....  
S/N ..... Date .....

**Air handling equipment**

Manufacturer .....  
Model # ..... S/N .....

Additional air handling units and accessories .....

**Preliminary equipment check**

Is there any shipping damage ? ..... If so, where ? .....  
Will this damage prevent unit start-up ? .....

- Unit is level in its installation
- Power supply agrees with the unit nameplate
- Electrical circuit wiring has been sized and installed properly
- Unit ground wire has been connected
- Electrical circuit protection has been sized and installed properly
- All terminals are tight
- All cables and thermistors have been inspected for crossed wires
- All plug assemblies are tight

**Check air handling systems**

- All air handlers are operating
- All chilled water valves are open
- All fluid piping is connected properly
- All air has been vented from the system
- Chilled water pump (CWP) is operating with the correct rotation. CWP amperage: Rated: ..... Actual .....

**Check condenser system (30HXC)**

- All condenser water valves are open
- All condenser piping is connected properly
- All air has been vented from the system
- Condenser water pump (CWP) is operating with the correct rotation.  
 Condenser water pump amperage: Rated: ..... Actual .....

**Unit start-up**

- CWP starter has been properly interlocked with the chiller
- Oil heaters have been energized for at least 24 hours (30GX)
- Oil level is correct
- All discharge and liquid valves are open
- All suction valves are open, if equipped
- All oil line valves and economizer discharge bubbler valves (30HXC only if equipped) are open
- Unit has been leak checked (including swagelock fittings)  
 Locate, repair, and report any refrigerant leaks

.....  
 .....  
 .....

Check voltage imbalance: AB ..... AC ..... BC.....  
 Average voltage = ..... (see installation instructions)  
 Maximum deviation = ..... (see installation instructions)  
 Voltage imbalance = ..... (see installation instructions)

- Voltage imbalance is less than 2 %

**WARNING**

*Do not start chiller if voltage imbalance is greater than 2 %. Contact local power company for assistance.*

- All incoming power voltage is within rated voltage range

**Check cooler water loop**

Water loop volume = ..... (liters)  
 Calculated volume = ..... (liters)  
 3.25 liters/nominal kW capacity for air conditioning  
 6.5 liters/nominal kW capacity for process cooling

- Proper loop volume established
- Proper loop corrosion inhibitor included ..... liters of .....
- Proper loop freeze protection included (if required) ..... liters of .....
- Piping includes electric heater tape, if exposed to the outside
- Inlet piping to cooler includes a 40 mesh strainer

**Check pressure drop across the cooler**

Entering cooler = ..... (kPa)  
 Leaving cooler = ..... (kPa)  
 (Leaving - entering) = ..... (kPa)

**WARNING**

*Plot cooler pressure drop on performance data chart (in product data literature) to determine total liters per second (l/s) and find unit's minimum flow rate.*

Total l/s = .....  
 l/s / nominal kW = .....  
 Total l/s is greater than unit's minimum flow rate  
 Total l/s meets job specified requirement of ..... (l/s)

**Check condenser water loop**

- Proper loop corrosion inhibitor included ..... liters of .....
- Inlet piping to condenser includes a 40 mesh strainer

**Check pressure drop across the condenser (30HXC only)**

Entering condenser = ..... (kPa)

Leaving condenser = ..... (kPa)

(Leaving - entering) = ..... (kPa)

**WARNING**

*Plot condenser pressure drop on performance data chart (in product data literature) to determine total liters per second (l/s) and find unit's minimum flow rate.*

Total l/s = .....

l/s / nominal kW = .....

Total l/s is greater than unit's minimum flow rate

Total l/s meets job specified requirement of ..... (l/s)

**Perform TEST function (indicate positive result):**

**WARNING**

*Once power is supplied to the unit, check the display for any alarms, such as phase reversal. Follow the TEST function instructions in the Controls and Troubleshooting literature.*

*Be sure all service valves are open before beginning the compressor test section. Items marked with "†" will indicate "ABSENT" unless A2 or B2 compressors are present.*

**<1> <TEST/ALRM>**

Loader A1

Loader A2

Minimum load valve A (FIOP)

Circuit A oil heater (30GX only)

A1 motor cooling solenoid

A2 motor cooling solenoid †

Circuit A oil pump

Oil solenoid A1

Oil solenoid A2 †

**<2> <TEST/ALRM>**

Loader B1

Loader B2

Minimum load valve B (FIOP)

Circuit B oil heater (30GX only)

B1 motor cooling solenoid

B2 motor cooling solenoid †

Circuit B oil pump

Oil solenoid B1

Oil solenoid B2 †

**<3> <TEST/ALRM>**

Fan 1 (30GX only)

Fan 2 (30GX only)

Fan 3 (30GX only)

Cooler pump

Condenser pump

Cooler heater (30GX only)

Alarm relay

Fan 4 (30GX only)

Fan 5 (30GX only)

Fan 6 (30GX only)

**<4> <TEST/ALRM>**

Circuit A EXV valve

Circuit B EXV valve

Circuit A water valve (if installed, 30HXC only)

Circuit A % fan speed (if installed, 30GX only)

Circuit B % fan speed (if installed, 30GX only)

Check for communicating modules (blinking red and green lights)

Correct fluid set points are entered

<1> <SET> Cool setpoint 1

Cool setpoint 2

Correct date and time is set (<4> <SET>)

Review and record factory/service configuration codes

<5> <SRVC>

Configuration code 1: .....

Configuration code 2: .....

Configuration code 3: .....

Configuration code 4: .....

Configuration code 5: .....

Review and record software version, <1> <SRVC>

Software version CESR500100 version

Review and record field configuration, <2> <SRVC>

Cooler fluid select .....	External reset sensor .....
Minimum load select .....	Cooler pump interlock .....
Loading sequence select .....	Cooler pump control .....
Lead/lag sequence select .....	Condenser pump control* .....
Head pressure control .....	Condenser flow switch* .....
Motormaster select* .....	Condenser water sensors* .....
Water valve type* .....	<i>*If installed</i>

**To start the chiller**

**WARNING**

*Be sure that all service valves are open, and all pumps are on before attempting to start this machine. Once all checks have been made, move the switch to "LOCAL" or "REMOTE" from "OFF".*

Unit starts and operates properly

**Temperatures and pressures**

**WARNING**

*Once the machine has been operating for a while and the temperatures and pressures have stabilized, record the following*

Cooler EWT .....	Ambient temperature (GX) .....
Cooler LWT .....	Condenser EWT .....
	Condenser LWT .....
Circuit A oil pressure .....	Circuit B oil pressure .....
Circuit A suction pressure .....	Circuit B suction pressure .....
Circuit A discharge temperature .....	Circuit B suction temperature .....
Circuit A suction temperature .....	Circuit B discharge pressure .....
Circuit A discharge pressure .....	Circuit B discharge temperature .....
Circuit A liquid line temperature .....	Circuit B liquid line temperature .....

**NOTES:**

.....

.....

.....

.....

.....

.....

.....

.....

.....

.....



BP 49 Route de Thil  
01122 MONTLUEL - FRANCE  
Tel: 04 72 25 21 21  
Telex: 900386  
Fax: 04 72 25 22 51